



# FOBO ULTRA

## User Manual

Version 1.3

(For iOS7.1 and Android 4.30 or later)

# Contents

- 1 Introduction**
- 2 About FOBO Ultra**
- 3 Importance of Tire Care**
- 4 Product Description of FOBO Ultra**
  - 4.1 In-Car unit/Repeater (TU1601)**
  - 4.2 Tire Sensor unit (TU1602)**
  - 4.3 Sensor lock nut & wrench**
  - 4.4 Extension Valve & Screw on T-valve**
  - 4.5 In-Car unit mounting and proposed location**
  - 4.6 Repeater mounting and proposed location**
- 5 Using FOBO Ultra**
  - 5.1 Description of FOBO Ultra App (for iOS)**
  - 5.2 Description of FOBO Ultra App (For Android)**
  - 5.3 Installing FOBO Ultra App**
  - 5.4 Installing FOBO Ultra In-Car unit and sensors**
  - 5.5 Sensor rotation**
  - 5.6 Disable sensor and Replace new sensor**
  - 5.7 Release (Total/Sensor)**
  - 5.8 Tire Inflation/Deflation**
  - 5.9 Drop & Hook**
- 6 In-Car unit audio & LED alerts**
- 7 Replacing Battery – Sensor, In-car and repeater**
- 8 Tire Changing Guideline**
- 9 Trouble Shooting Guide**
- 10 FOBO Ultra Specifications**
- 11 Warning**
- 12 Regulatory Information**
- 13 Intellectual Properties**
- 14 Limited Warranty and Disclaimer**

# 1 Introduction

FOBO Ultra is the world's most advanced Tire Pressure Monitoring System (TPMS) using Bluetooth Smart (Bluetooth 4.1 or later) technology to monitor your Truck, RV, Caravan tire pressure and temperature. Bluetooth Smart is a very low power wireless technology that could operate on a single coin cell battery for up to twelve months (**NOTE: Battery life may vary according to usage and climatic temperature. Operating under extreme cold may drastically reduce battery life.**)

Please ensure that your smartphone has Bluetooth Smart Ready (Bluetooth 4.1 or later) capability in order to use FOBO Ultra. Currently FOBO Ultra works best with iOS 7.1 and Android 4.30 or above.

Before starting to use FOBO Ultra, please download the free FOBO Ultra App to your smartphone from Google Play Store or Apple AppStore.

FOBO Ultra is a product designed and produced by Salutica Allied Solutions Sdn. Bhd. ("Salutica"), a Malaysian company with its address at No. 3, Jalan Zarib 6, Kawasan Perindustrian Zarib, 31500 Lahat, Ipoh, and Perak, Malaysia.

## 2 About FOBO Ultra

FOBO Ultra monitors your vehicle tires non-stop around the clock. Most drivers have encountered situations where they need to rush for an urgent delivery only to be stranded by a flat tire. Conventional Tire Pressure Monitoring Systems (TPMS) could not alert you in advance because it stops operating as soon as the Vehicle ignition is switched-off. With FOBO Ultra, you will get an alert as soon as the tire pressure drops below a certain pre-set level, even when the Vehicle ignition is switched off as long as you are within Bluetooth range (up to 30 meter with line of sight; but the range may reduce by obstacles in between). This alert gives you time to get the flat tire fixed before you need to use it.

FOBO Ultra can monitor up to 20 vehicle profiles on each smartphone. You can receive data from the tire pressure sensors from all your vehicles without switching on the ignition. FOBO Ultra allows you to monitor your Vehicle tires conveniently at any time you want. **NOTE: Under certain conditions the signals from FOBO Ultra sensors may be blocked by surrounding objects or structures. If this occurs, please move around the vehicle in order to capture signals from all the tire sensors.**

If you are sharing your vehicle with others, you (FOBO Sharer) can authorize others (FOBO Sharee) to use your FOBO Ultra through the FoboShare function.

After adding them through FoboShare, FOBO Sharees who use your vehicle will receive alerts and data from your FOBO Ultra on their respective smart phone which is installed with FOBO Ultra App. Refer Details at Section 5.3

FOBO Ultra packaging consists of 4 wireless tire sensors, 1 wireless In-Car unit or Repeater and a 24V 10 feet power cable with connector to In-Car or Repeater. Replace your vehicle tire valve caps with the sensors and place the In-Car unit inside the cab. The sensors will measure tire pressure of each tire and transmit via Bluetooth to the In-Car unit and your smartphone. In case of a breach of pre-set threshold of tire pressure, the In-Car unit will produce an audible alert to notify you. An alert will also pop up on your smartphone if it is within Bluetooth range.

FOBO Ultra system requires a qualified smartphone and FOBO Ultra App for installation. In addition to being able to view information regarding your vehicle tire pressure and temperature, the FOBO Ultra App will also produce an alert when your tire has a problem.

**DISCLAIMER: FOBO ULTRA IS NOT A DEVICE THAT PREVENTS ACCIDENTS. IT IS ALSO NOT A DEVICE THAT PREVENTS TIRES FROM BECOMING DEFLATED OR OVERINFLATED. FOBO ULTRA IS NOT A SUBSTITUTE FOR SAFE TIRE MAINTENANCE PRACTICES. PLEASE CONTINUE TO TAKE PRECAUTIONARY MEASURES WHILE DRIVING AND TAKE FULL RESPONSIBILITY OF YOUR VEHICLE'S TIRE CONDITION TO ENSURE SAFETY WHILE DRIVING. YOU SHOULD CONTINUE TO PRACTICE PROPER TIRE CARE AND SCHEDULED TIRE MAINTENANCE.**

### 3 Importance of tire care

It is extremely important to ensure vehicle tires are properly inflated for safety while driving. However, many drivers tend to neglect proper tire care and maintenance. The vehicle tires are the only contact points between the vehicle and the road. The weight of the vehicle and passengers are supported by the air pressure inside the tires. Improperly inflated vehicle tires may cause serious accidents on the road.

When tires are underinflated, the additional rolling resistance may cause buildup of heat which may lead to the de-lamination of the tire materials as well as damage to the tire's sidewall, which in turn increases the chances of a tire blow-out. Underinflated tires will also cause accelerated wear on the tire shoulders thereby causing uneven tire wear. Gas mileage will also be affected due to additional rolling resistance when driving with underinflated tires. You would also experience a significant loss of steering precision and cornering stability. Significantly under-inflated tires will also be less effective in resisting hydroplaning.

On the other hand, an overinflated tire will cause accelerated wear on the center portion of the tire resulting in uneven tire wear. It would also result in a harsher ride and makes the tire more susceptible to damage when going over potholes or debris on the road..

What is the optimum tire pressure? There are a lot of information about this subject in internet forums and web articles. A quick guide for better understanding of tire pressure below:-

- 1) Vehicle manufacturers recommend the optimum tire pressure for their vehicle models. The information is usually available on a sticker at the door jam (side of the driver's door) or in the owner's manual. For some vehicle models, the information sticker may be on the trunk lid or on the fuel door. Vehicle manufacturers usually recommend different tire pressure for front and rear axles. This pressure is usually recommended for comfort driving and optimum performance of the vehicle. It is not advisable to go below this recommended pressure level.
- 2) The vehicle manufacturer recommended tire pressure is "cold pressure". When you drive your vehicle to the gas station, the friction on the road will heat up your vehicle tires within a few minutes. Typically there will 1 psi (~7kPa) increase in air pressure for every 10 deg F (5.6 deg C) rise in temperature. It is advisable to inflate the tire pressure with this compensated pressure above the recommended pressure.
- 3) Air pressure in tires is affected by changes in temperature. Check and adjust your tire pressure whenever there is a drastic change in environment temperature, e.g. Change of season.
- 4) A tire will normally lose its pressure through natural causes unless accelerated by a puncture, faulty valve or damaged wheels. It is advisable to change the tire valves or at least check the valves condition every time you change a new set of tires. Under normal condition, a set of tires could deflate at a rate of up to 2psi per month. It is good practice to check your tire pressure regularly and top up to the optimum pressure.
- 5) Every vehicle tire has a maximum inflation pressure. It is not advisable to inflate to the maximum inflation pressure of the tire. Follow the vehicle manufacturer's recommended tire pressure instead.

## 4 Product Description of FOBO Ultra

### 4.1 In-Car Unit (TU1601)



The functions of three action buttons are to correspond with the instruction that appears on the screen.

**NOTE: Excessive frequent pressing on the buttons will drain the In-Car unit battery.**

Status indicator	- Red LED will blink to show startup mode or battery low status. - Amber LED will blink to show alerts, low sensor battery and missing sensor.
Alert buzzer	- buzzer to alert when there is problem with tire
AA batteries	- In-car unit/Repeater operates with 5AA size batteries.

The FOBO Ultra In-Car unit/Repeater is a complex device that performs multiple functions. Due to the shielding effect of the vehicle chassis, some drivers may face

difficulty in receiving the tire sensor signals on their smartphone when sitting inside the cab. This problem may be further aggravated when the driver places the smartphone in positions that are not optimal such as trouser pocket or waist pouch. The In-Car unit is designed with an efficient antenna that can pick up sensor signals better than a usual smartphone, enabling good signal reception from the tire sensors. Keep the In-Car unit in the cab and fix the Repeater in the center of the Trailer for optimal functioning of FOBO Ultra. You may remove it for other sensor operation purposes, such as sensor position rotation and sensor disabling but place it back once the sensor operation is completed. **Note that In-Car unit is not waterproof.**

**Fobo Ultra In-car unit Dimensions in mm:**

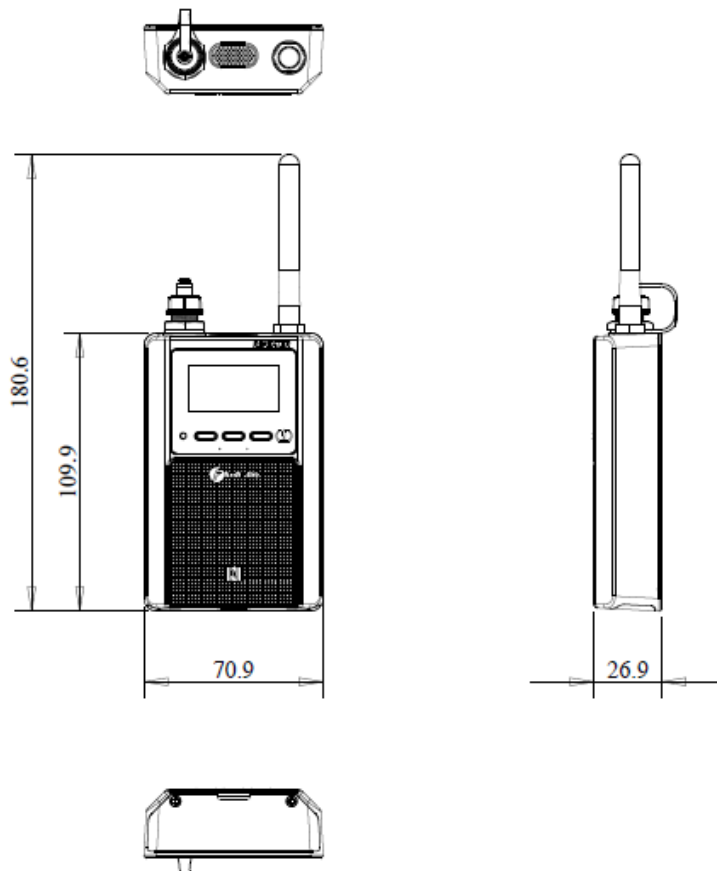

### FOBO Ultra Repeater Dimensions in mm:

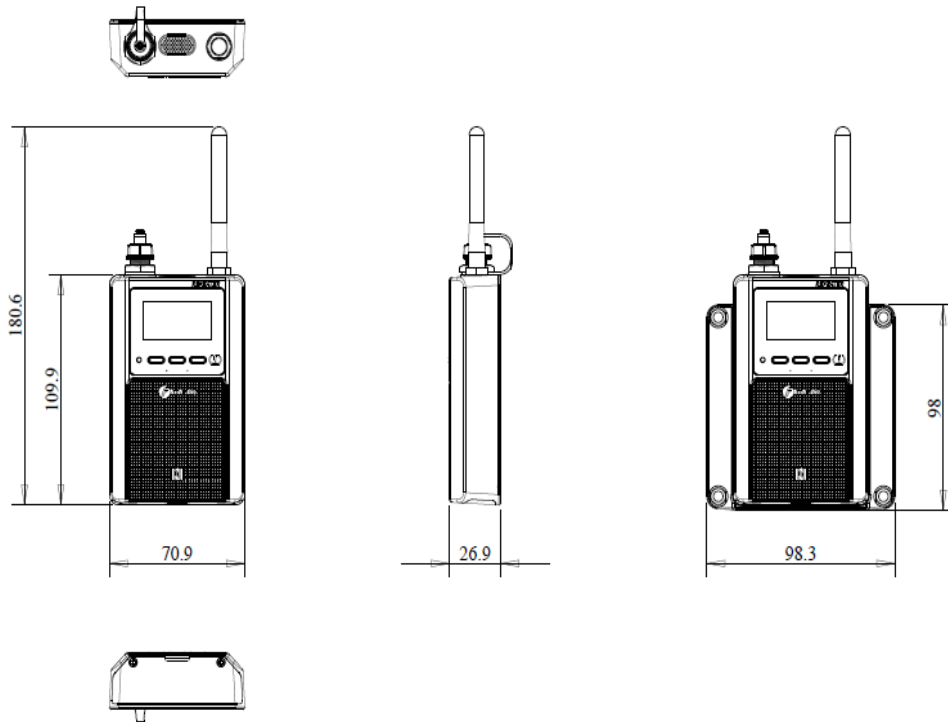

To conserve battery life, the In-Car unit/Repeater will go into ‘sleep’ mode after it detects that the vehicle has been stationary for more than 15 minutes. It will ‘wake up’ once it detects that the vehicle moves. You can still receive your tire pressure and temperature data by accessing the FOBO Ultra App on the smartphone, even when the In-Car unit is asleep. This is due to FOBO Ultra sensor’s continuous operation of 24 x 7 which allows you to receive an alert even when the vehicle’s ignition is switched off.

The In-Car unit/Repeater is also designed to be a secondary alert device in the event of a deflated tire. This is to cover situations when you do not have your smartphone with you while driving or if your smartphone’s battery is dead. When there is a tire pressure alert, the In-Car unit/Repeater will produce an audible and visual LED alerts to inform you of a tire pressure problem.

**Note:** In the scenario if user planning not to use the vehicle which is installed with FOBO Ultra In-car unit/ Repeater unit for more than 1 week then it is advisable to remove the in-car unit/Repeater battery.

User have choice to choose the power source to power up the in-car unit/Repeater unit, they can choose to use Batteries (using 5AA Batteries) which are pre-installed



in the In-car/Repeater or they can choose to use external power source by using power cable which is provided in the FOBO Ultra packaging box. It is recommended to use In-car /Repeater with external power source.

## 4.2 Tire Sensor Unit (TU1602)

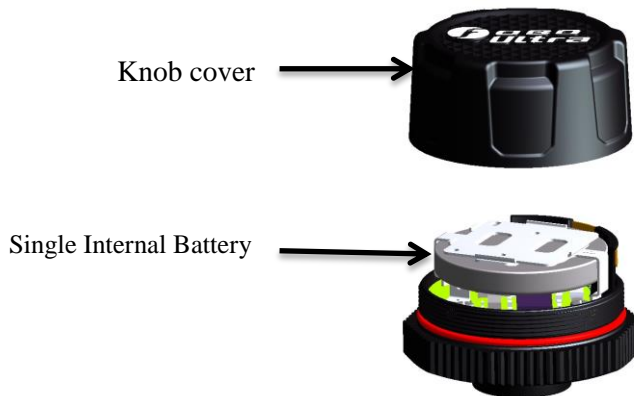

- Knob cover – waterproof cover. Please ensure the red silicon ring is intact to prevent water from getting into electronics compartment.
- Single internal battery - CR2032 coin cell battery. When replacing battery, please ensure the “+” sign of the battery is facing up, away from PCB.
- Internal PCB - internal electronics circuit (The pressure sensor chip is mounted within this PCBA, and it senses the tire pressure against a built-in vacuum, resulting in an Absolute Pressure reading. The internal firmware will then subtract the sea-level pressure of 101.3 Kpa (14.7 psi) from this reading. This final reading which will be shown in the App can be termed as i) Tire **Absolute Pressure minus sea level pressure**, or ii) Gage Pressure reference to sea-level altitude. With this formulation, Fobo Ultra sensor will read the same pressure value for any given time, irrespective of altitude (assuming a constant temperature). This will ensure the correct tire

footprint per vehicle manufacturer's pressure recommendation, for all altitude above sea-level, given a constant temperature.

As a corollary, a tire with a Fobo reading of, say 40 psi at an altitude of 5000ft, will read the same 40 psi when driven to sea-level, given a constant temperature. In reality, it will read higher due to the warmer temperature at sea-level, and may need some air release if the temperature difference is great. Tire pressure generally will increase 1 psi (~7kPa) for every 10 deg F (5.6 deg C) rise in temperature.

FOBO wishes to highlight the above formulation is for usage at sea-level and above, and will not be accurate for use otherwise. In practice, this should not be an issue as the lowest area on earth will result in an insignificant error of 0.3 psi (~2 Kpa).

For users who wish to retain 'Gage Pressure Reading', the FOBO Ultra App has a Gage Pressure, adjusted to local altitude using cell towers or individual phone barometer if available. This Gage Pressure button can be accessed from the App (Kindly refers to Section 5.10 of this user manual).

FOBO Ultra sensor units are designed to be robust and operate reliably 24x7 to provide tire information around the clock. It is designed to be water proof and by our special use of custom engineering plastics, it will be able to withstand road salts or other common automotive chemicals (petrol, engine oil, wash shampoo, etc.).

Our designers have designed the sensors to ensure that there is no air leakage as it replaces the tire's original valve cap. There is no need to screw on the sensor extremely tight. Apply a reasonable hand twist force to ensure the sensor is securely installed and should be able to be removed by hand with ease.

When installing the sensors, please follow the on-screen prompt of the In-car unit. After installation, in the event the tire sensors positions are mixed up, usually after performing a tire rotation maintenance, you can easily re-position the sensors to their correct position by selecting 'sensor rotation' on

the in-car unit and follow the on-screen instructions. This eliminates the need to remove the tire sensors physically.

A missing or damaged tire sensor can be replaced easily through the In-car unit. You will need to purchase a replacement sensor which you can do so online at [www.my-fobo.com](http://www.my-fobo.com). To replace the sensor, first select 'Disable Sensor' on the In-car unit under sensor Management system and the pop-up will prompt you to tap on the tire position that you want to disable. Then, select 'Replace sensor', upon selecting the app will blink at the first disabled position and the App will prompt you to install the replacement sensor. Follow the on-screen instruction and the replacement sensor will be paired and be ready to use.

**FOBO Ultra sensor dimensions in mm:**

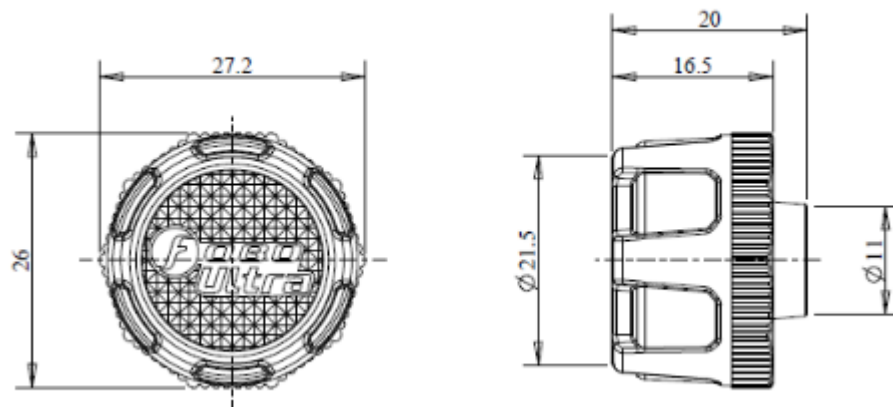

**NOTE:** Battery life span up to Twelve months is an estimate based on normal use at 23 °C. Battery life may vary according to usage and climatic temperature.

**Battery life span will change due to the following reasons:**

- 1) Frequent change of pressure threshold setting in the App.
- 2) Disabling & enabling of sensors.
- 3) Release & pairing.
- 4) Removal & screw-on of sensors.
- 5) Operating under extreme cold/hot temperature.
- 6) Testing of product.
- 7) Rotation (refer section 5.4 of this user manual)
- 8) Trigger alert or let activated alerts unattended.

9) Multiple removal and screw-on of sensors for equalizing all tire pressures.

All these activities will drain a battery very fast and affect the battery life span.

### 4.3 Sensor Lock nut and wrench



FOBO Ultra sensors and In-Car unit are tied to a FOBO account after installation. They are not re-usable or transferable without the owner releasing them from his/her FOBO account. This is a theft deterrent feature to discourage theft.

As an additional anti-theft feature, all FOBO Ultra package comes with lock-nuts and special wrench. FOBO Ultra functionality is not affected if you do not use the lock-nuts.

The lock nuts and wrench are made of custom engineering plastics that can withstand road salts and common automotive chemicals (gasoline, engine oil, wash shampoo, etc.).

In order to use the lock nuts, you must first install the lock nut to the tire valve (with the bump facing tire rim). Screw in the lock nut all the way down and ensure that there is still a **minimum of 5 thread count** on the tire valve for the sensor unit to be screwed on. If there is insufficient thread for the tire sensor, it may lead to air leakage. A solution for this would be to change the tire valve to one with a longer thread. Next, screw in the tire sensor unit until

it is reasonably tight. Then use your finger to unscrew the lock nut outwards (i.e. anti-clockwise) until it pushes against the bottom of the sensor unit. Use the wrench to tighten the lock nut. The resultant friction force will make it difficult to remove the sensor unit without loosening the lock nut. For rubber valves, hold the valve stem with one hand and tighten the lock nut with the wrench on another hand. This is to avoid the rubber valve from twisting making it unable to tighten the lock nut.

**WARNING: Do not apply too much force to tighten the lock-nut. You may face difficulty to loosen the lock nut later on especially for rubber valves that typically doesn't stay firm on the tire rims.**

**NOTE: If your tire valve is too short, you shouldn't use the lock nut as this will block the sensors from being completely screwed on the tire valve and causes air leak. Our sensors are designed to work on a tire valve with a minimum of 5 thread counts.**

### Step by step diagram to use FOBO Ultra Lock Nut and wrench

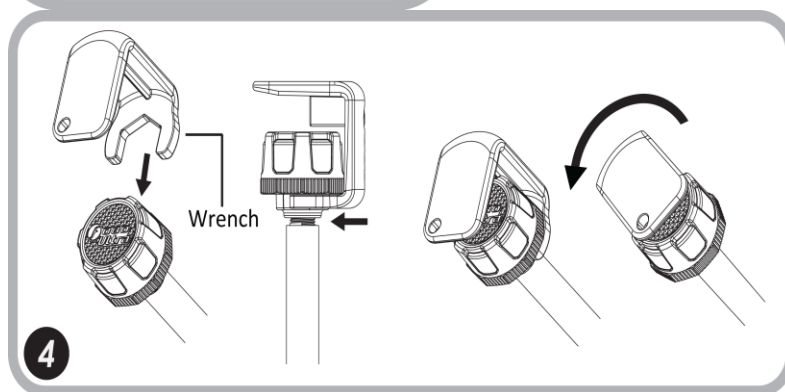
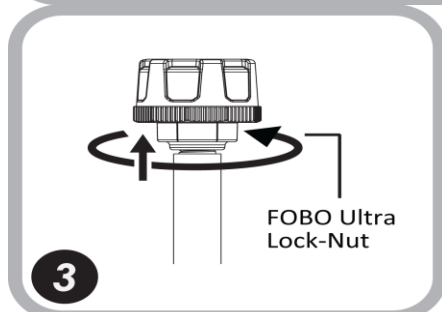
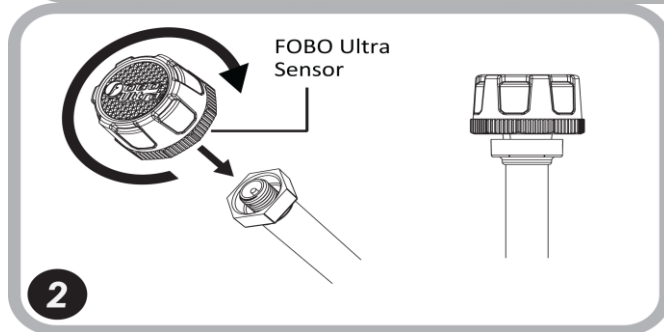
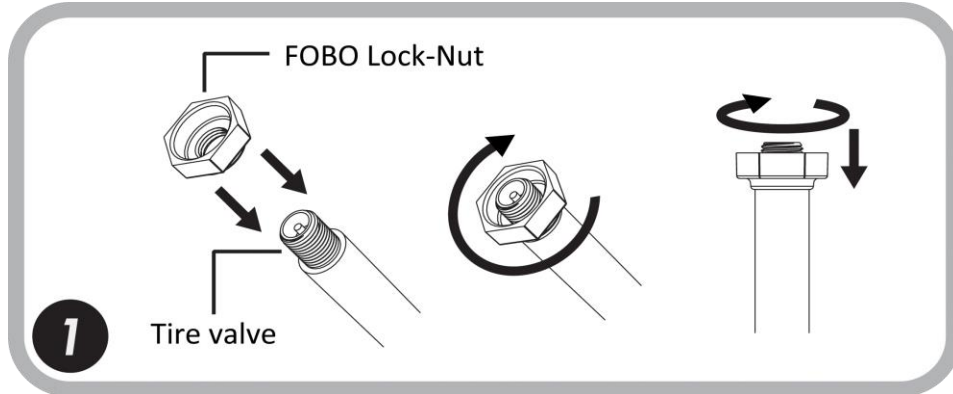

## 4.4 Extension Valve & Screw-on T-valve

Extension Valves are helpful when inflating wheels fitted with short or difficult to reach tire valves. Extension valve is suitable for inner tire valve stem in axles with 4 wheels. The ends of these extensions are easily accessible with plenty of clearance.

**Step by step pictures to use Extension Valve & Screw on T-valve**

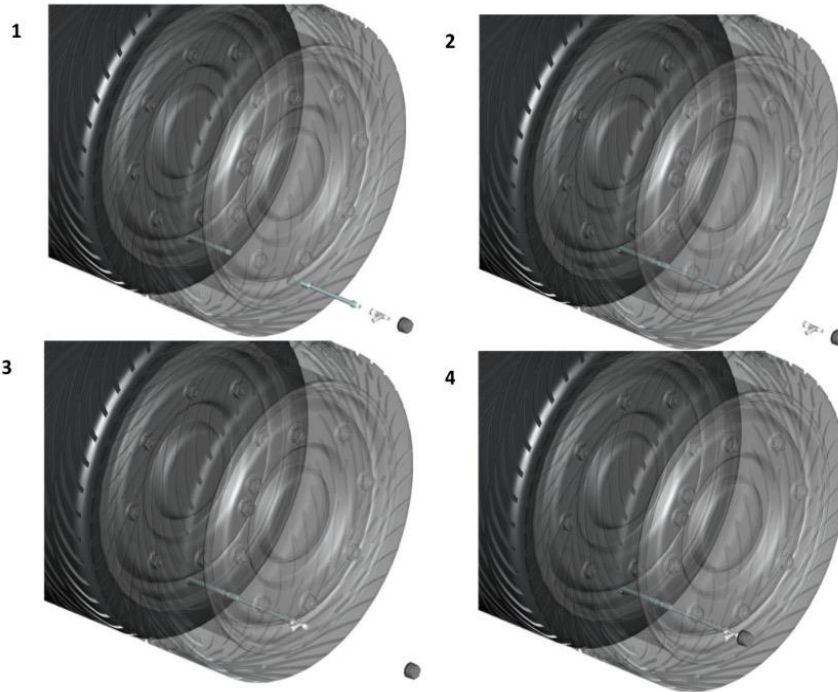

**Screw on T-valve and Extension valve Dimensions:**

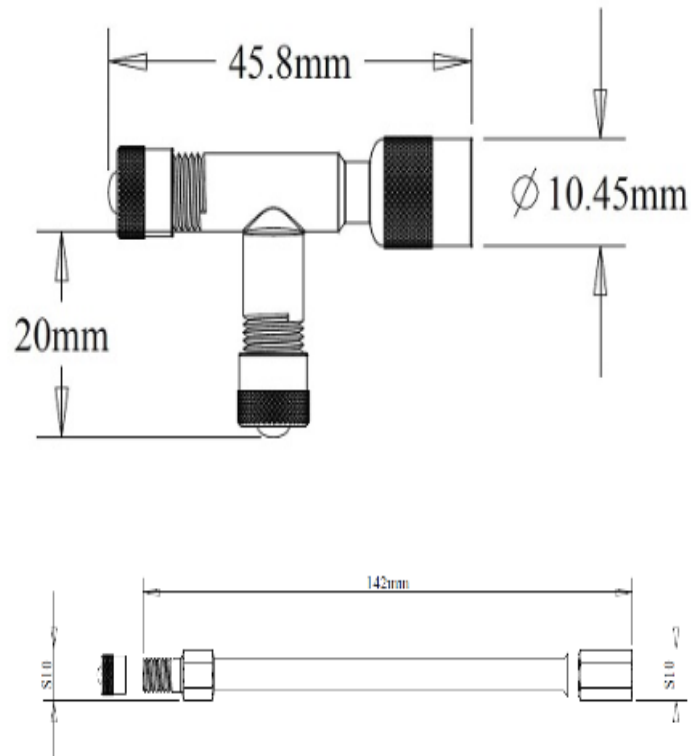

To purchase Extension Valve & Screw-on T-Valve you can write in at [fobo@salutica.com.my](mailto:fobo@salutica.com.my).



## 4.5 In- Car unit mounting and proposed location

It is advisable to mount the In-Car unit at the proposed location in the cab for better signal reception. This proposed in-car unit location will ensure the maximum signal reception from all the sensors. Refer to the illustration below showing mounting and proposed location:

### IN-CAR FIXING METHOD AND PROPOSE AREA (LEFT SIDE DRIVER)



**VELCRO HOOK**

**STEP 2- ADHERE VELCRO HOOK ONTO FRONT LEFT PILLAR (PROPOSE LOCATION)**

**VELCRO LOOP**

**STEP 1- ADHERE VELCRO LOOP ONTO IN-CAR BACK SIDE. (WITHIN RECESS AREA)**

**IN-CAR**



**IN-CAR FIXING METHOD AND PROPOSE AREA (RIGHT SIDE DRIVER)**



**VELCRO HOOK**

**STEP 2- ADHERE VELCRO HOOK ONTO FRONT RIGHT PILLAR (PROPOSE LOCATION)**



## 4.6 Repeater mounting and proposed location

Refer to the illustration below, showing repeater mounting and proposed location:

### Step 1:

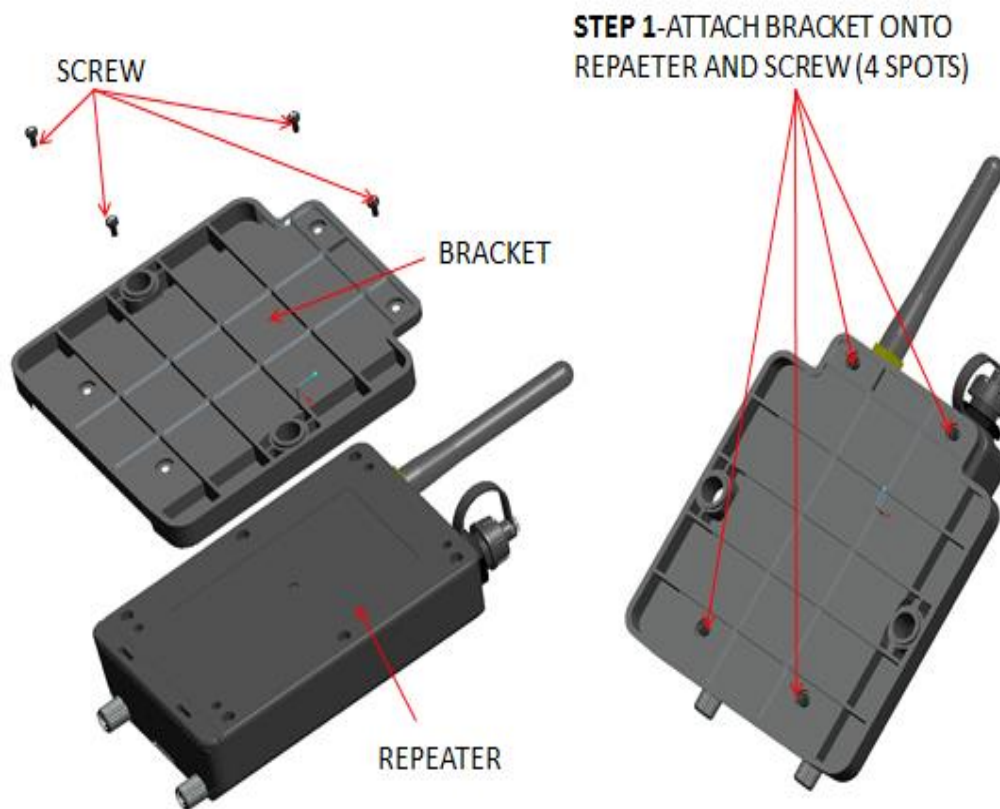

## Step 2 & 3:

**STEP 2-** FIND FIXING LOCATION WHICH IS EASY TO FIX. PROPOSE TO FIX THE REPEATER ONTO TRAILER HORIZONTAL BAR WHICH LOCATED JUST AFTER THE GROUP OF REAR TIRES.

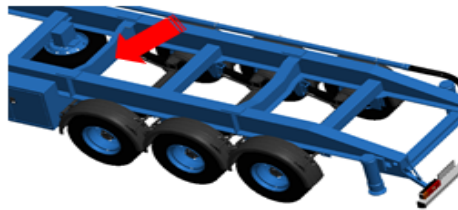

**STEP 3-** DRILL 2 HOLES AS BELOW DIMENSIONS

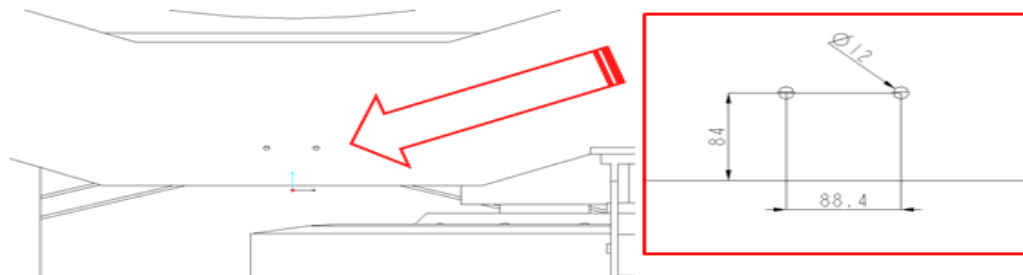

## Step 4:

**STEP 4-** ATTACH THE REPEATER UNIT ONTO HORIZONTAL BAR AND FIX BY 2 M8 BOLTS AND 2 M8 NUTS. MAKE SURE THE ANTENNA IS FACING DOWNSIDE.

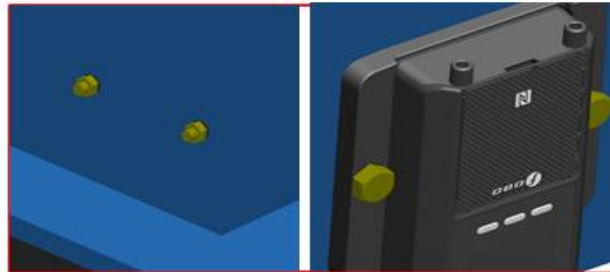

## 5.1 Description of FOBO Ultra App (For iOS)

### 5.1.1 FOBO Ultra App login page (For iOS)



**E-mail address** - Your FOBO account and vehicle profile information will be referenced to this e-mail address. Please use a valid e-mail address.

**Login button** - click here to login after you have registered and activated an account.

## 5.1.2 FOBO Ultra App home page (for iOS)

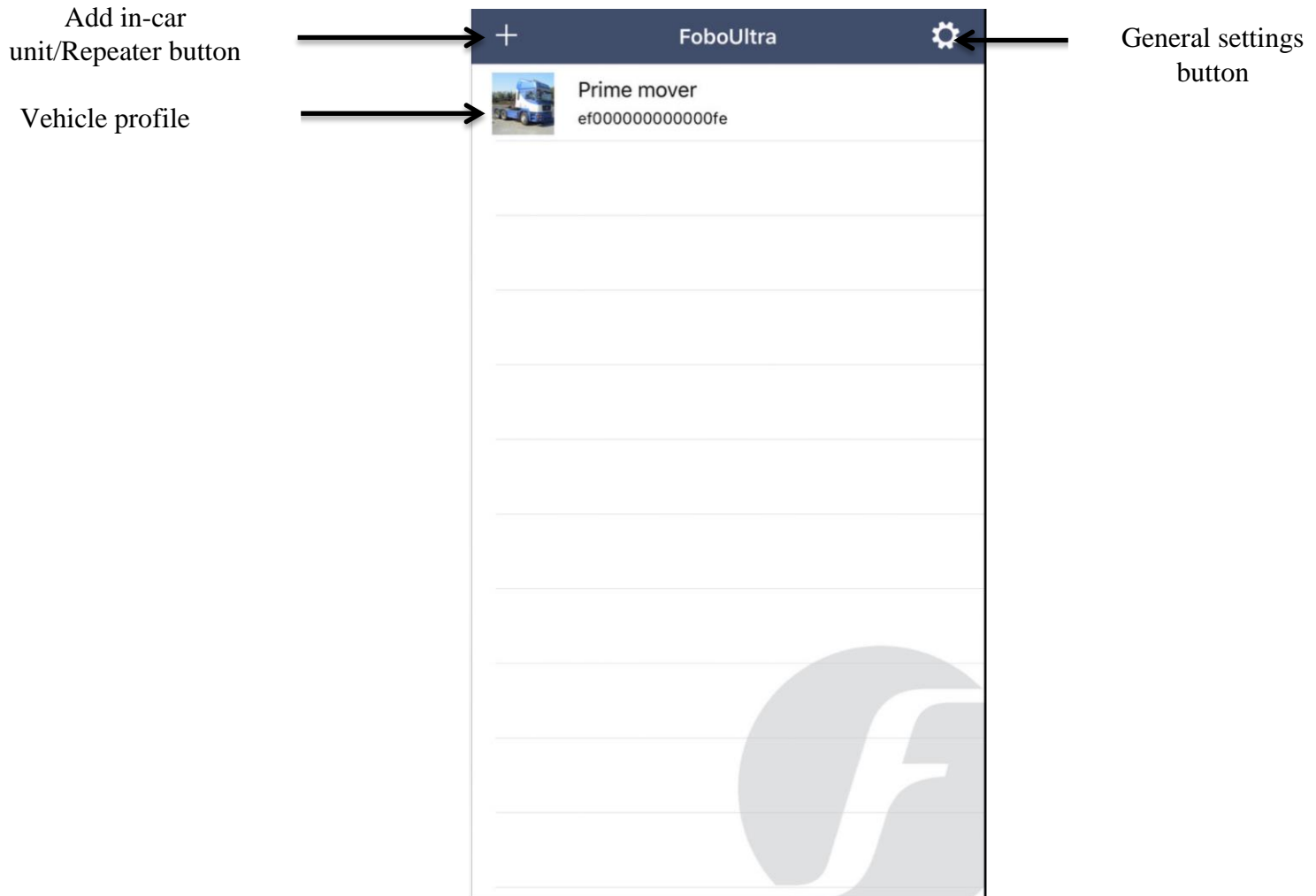

**Add Tag button** – Click here to add new in-car unit/Repeater to your FOBO account.

**General settings button** – Click here to get to general settings screen.

**Vehicle Profile** – Click here to get to detail page/Vehicle status page.

### 5.1.3 General Settings page (for iOS)

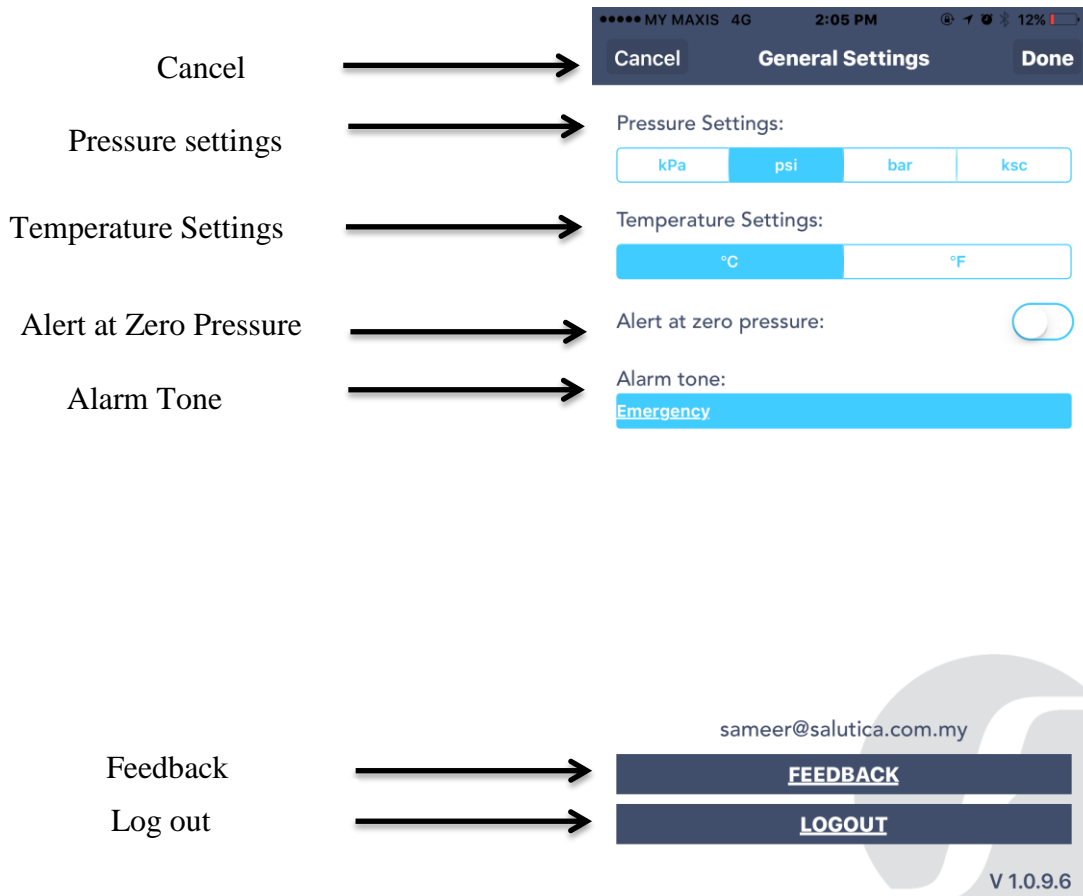

**Cancel** – Click here to get back to FOBO Ultra App home page.

**Pressure settings** – To choose preferred pressure units.

**Temperature settings:** To choose preferred temperature units.

**Alert at Zero pressure** – Turn on to receive alert at zero pressure.

**Alarm Tone** – To choose type of alarm tone.

**Feedback** – To contact FOBO Customer service.

**Logout** – To log out from the App.

### 5.1.4 FOBO Ultra App detail page (For iOS):

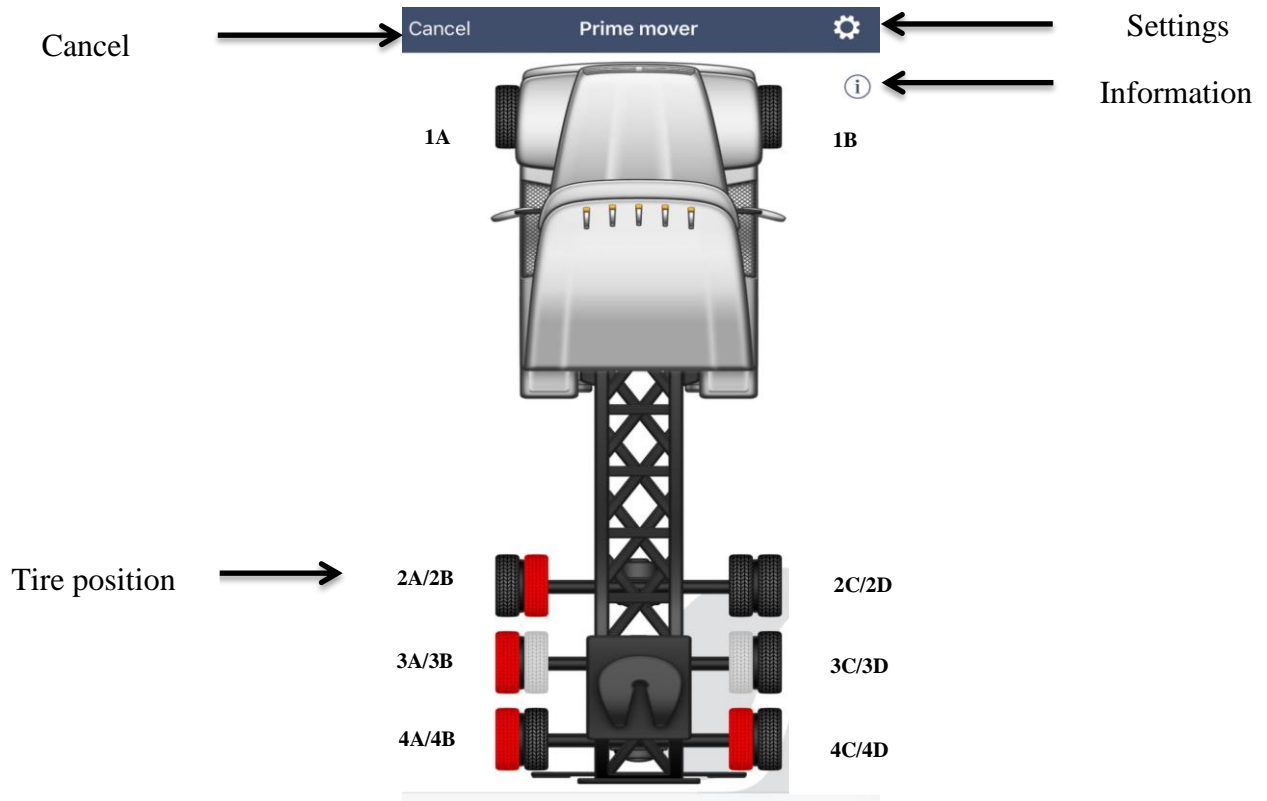

**Cancel** - Click here to get back to FOBO Ultra App home page.

**Tire Position** – Click on the tire position to get Pressure and temperature readings.



**Information** – Click here to get details of what each color tire represents.

**Information:**



Sensor not Installed



Sensor disabled



Sensor updated



Sensor not updated



Warning

**OK**

**Settings** – Click here to set Pressure thresholds, change picture, FOBO Share, Type of vehicle, Vehicle name.

**Note:** Sensor positions shown above are meant for illustration of the concept.

### 5.1.5 FOBO Ultra App Settings page (For iOS):

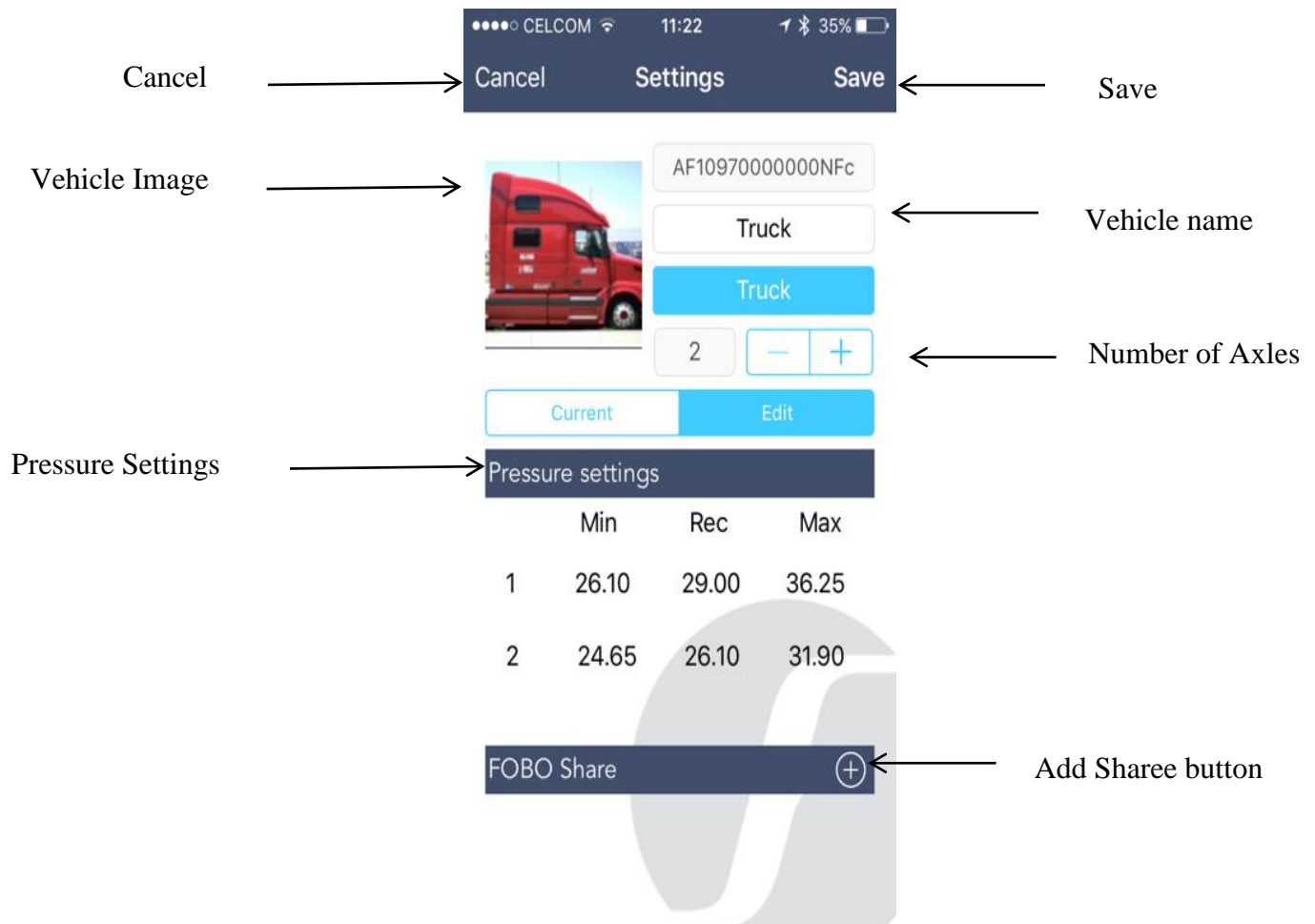

**Cancel** – Click here to get back to FOBO Ultra App detail page.

**Vehicle image** – Click here to capture vehicle image.

**Pressure settings** – Click here to set Min/Rec/Max pressure thresholds.

**Add sharee button** – Click here to add sharee.

**Vehicle Name**- Click here to key in vehicle name.

**Save** – Click here to save the settings.

**Number of Axles** – Click here to choose number of Axles.

## 5.2 Description of FOBO Ultra App (For Android)

### 5.2.1 FOBO Ultra App Home page (For Android)

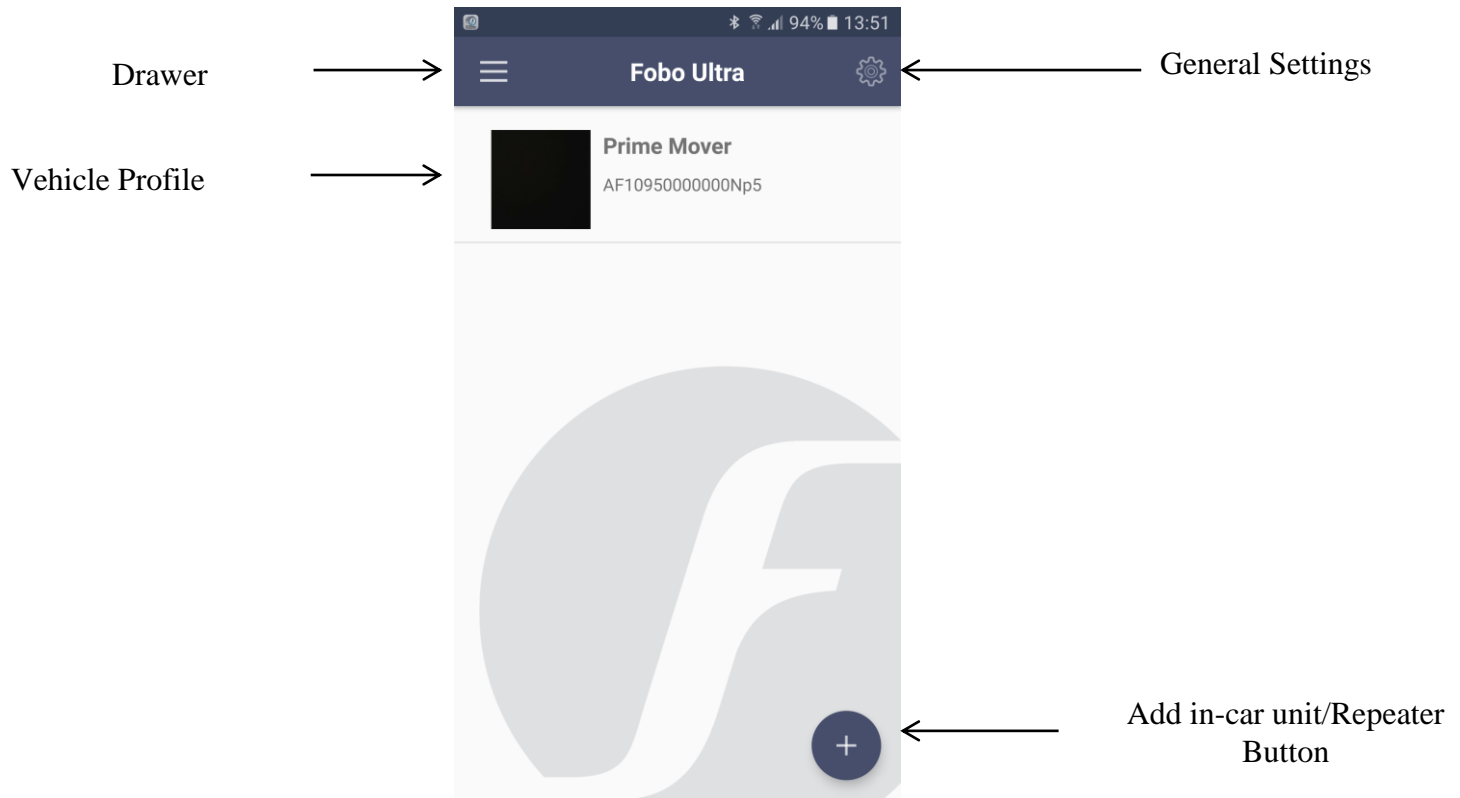

**Vehicle profile** – Click here to get to detail page/Vehicle status page.

**Add in-car unit/ Repeater Button** - Click here to add new in-Car unit/Repeater to your FOBO account.

**General Settings** - Click here to get to general settings screen.

**Drawer** – Click here to get In-car list, Pair with an in-car, General Settings, Application information, Log out and Feedback.

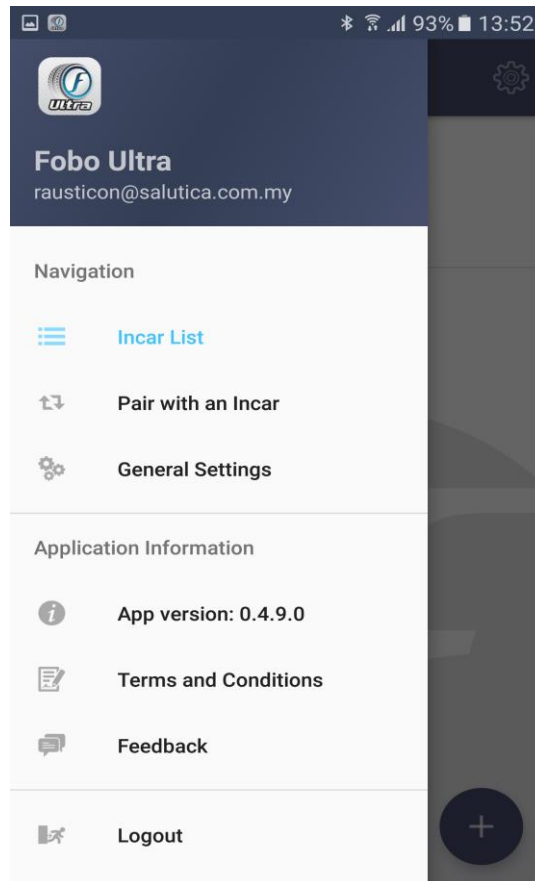

## 5.2.2 General Settings page (for Android)

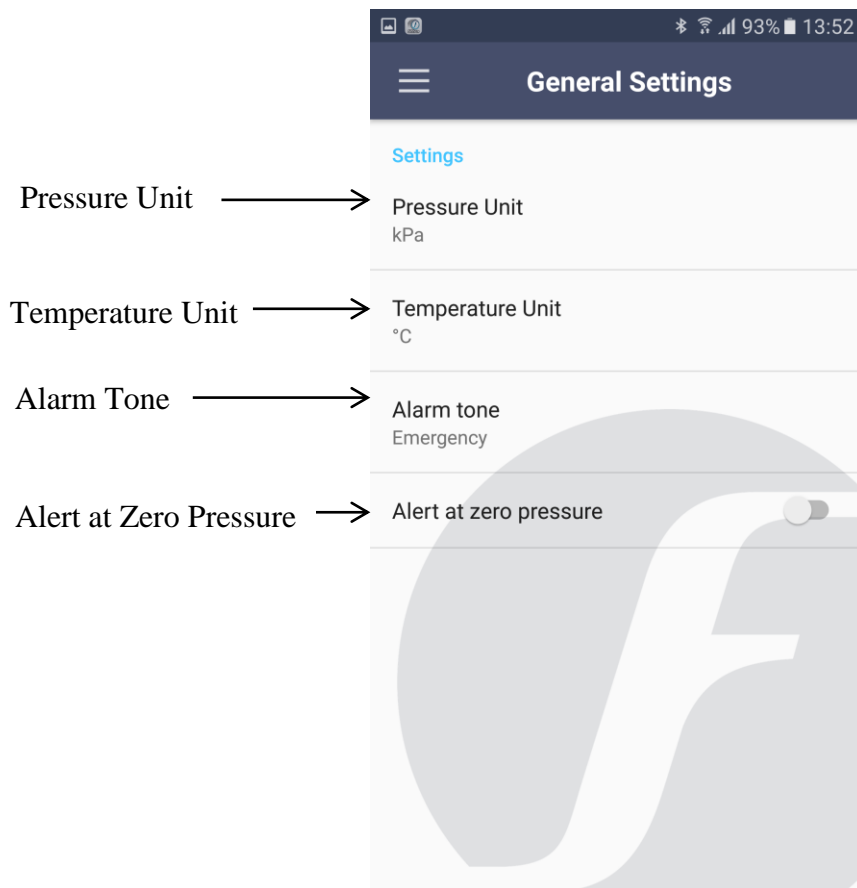

**Pressure Unit** – To choose preferred pressure units.

**Temperature Unit:** To choose preferred temperature units.

**Alarm Tone** – To choose type of alarm tone.

**Alert at Zero pressure** – Turn on to receive alert at zero pressure.

### 5.2.3 FOBO Ultra App detail page (For Android):

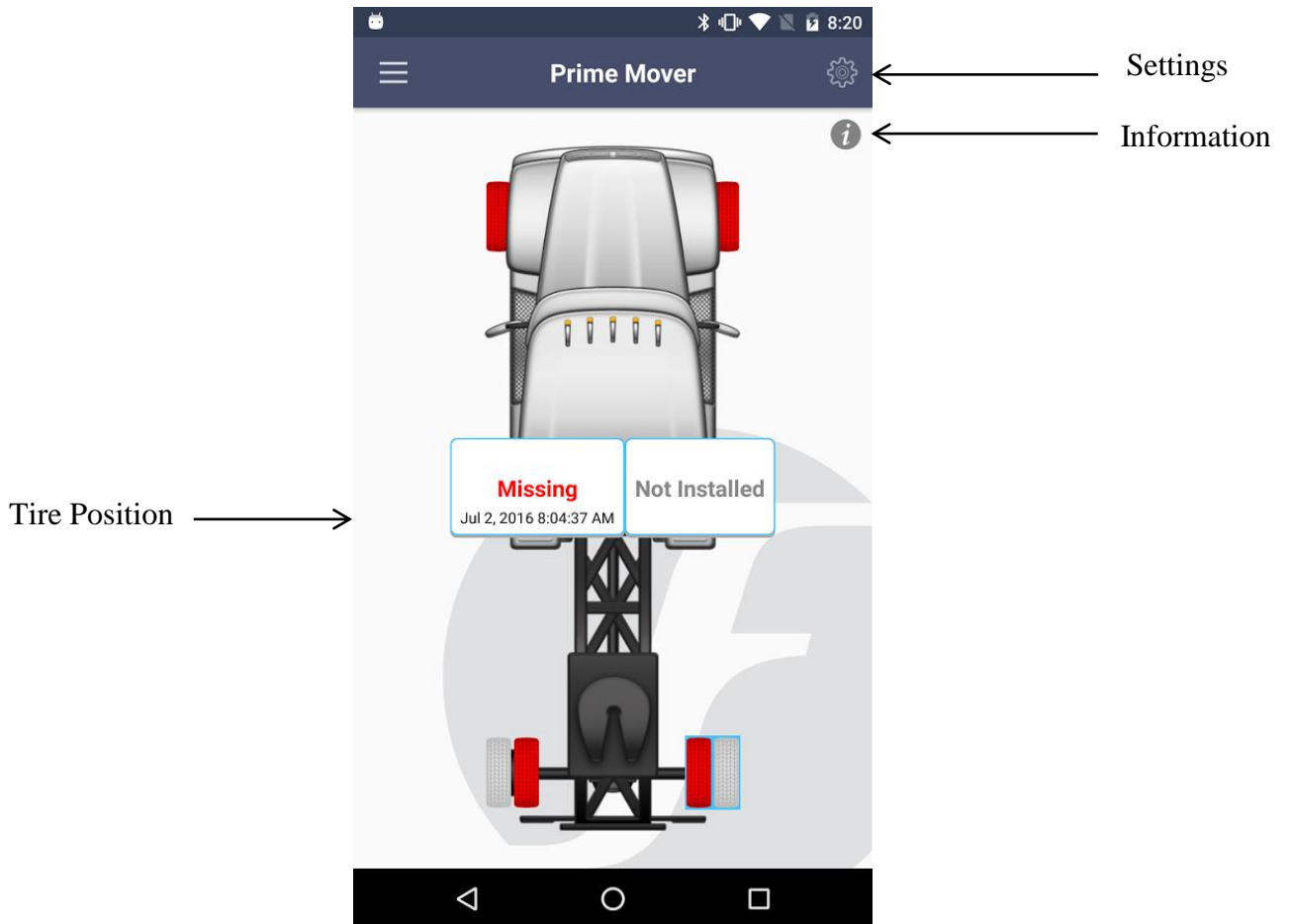

**Tire Position** – Click on the tire position to get Pressure and temperature readings.

**Information** – Click here to get details of what each color tire represents.

**Settings** – Click here to set Pressure thresholds, change picture, FOBO Share, Type of vehicle, Vehicle name.

### 5.2.4 FOBO Ultra App Settings page (For Android):

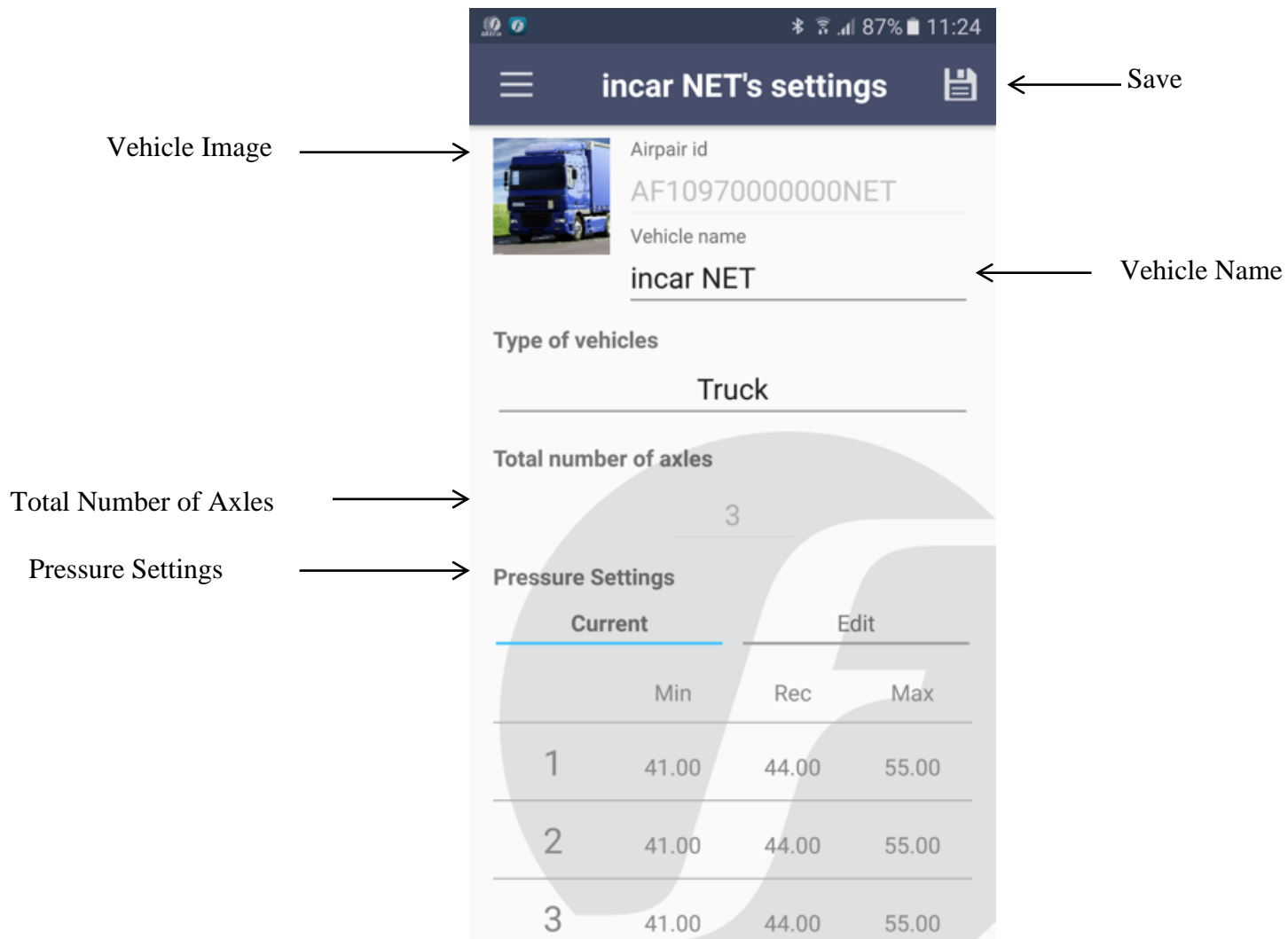

**Vehicle image** – Click here to capture vehicle image.

**Total Number of Axles** – Click here to choose total number of Axles.

**Pressure settings** – Click here to set Min/Rec/Max pressure thresholds.

**Vehicle Name-** Click here to key in vehicle name.

**Save** – Click here to save settings.

## 5.3 Installing FOBO Ultra App

You are required to have a smartphone with **Bluetooth 4.0** (Bluetooth Smart) capability in order to use FOBO Ultra. The smartphone must also be running on iOS 7.1 or Android 4.3 or later. Follow the steps below to install your FOBO Ultra:

**Step 1:** Download the FOBO Ultra App onto your smartphone

- For iPhone users, download from Apple's AppStore. For Android users, download from Google Play. Search for "FOBO Ultra".

**Step 2:** Launch the FOBO Ultra App & key in your email address

- For new users, key in your email address and click login.
- You will receive an email from FOBO with an activation link.
- Click on the activation link that you receive in your email.
- Once activated, go back to the FOBO Ultra App and click on login again.
- You be brought to the App's Home screen.

### Note:-

- An activation e-mail message will be sent to your e-mail address when you click on login as a first time user.
- If you do not receive this activation e-mail from FOBO Admin, please check your e-mail address entry to ensure it is valid without typo error.
- This e-mail may also be filtered by some e-mail servers. Please check your Spam mailbox.
- If you still do not receive any message from FOBO Admin after 15 minutes (with a good internet connection), please write in to [fobo@salutica.com.my](mailto:fobo@salutica.com.my) with your sign-in email.

### **IMPORTANT:**

**The email activation is to ensure that your account signup is done securely. FOBO Ultra is locked to your FOBO account as an anti-theft deterrent. Stolen sensors cannot be used by anyone else other than the FOBO account owner.**

**Location service is required to be enabled for the FOBO Ultra App (FOBO Ultra does not use the GPS function to track your location). The location service on the iOS/Android system has other functionality that**



the FOBO Ultra App uses to operate properly and to sync with the In-Car unit. It will ensure FOBO Ultra functions as designed, mainly for alert functions, and also the gauge pressure feature as required by users living at high altitudes. FOBO Ultra is designed to be a low energy system and does not drain your smartphone battery excessively.

By submitting your information to sign up a new user account, you acknowledge your acceptance to the terms and conditions of our Software Licensing Agreement and Privacy Policy.

## **5.4 Installing FOBO Ultra In-Car unit/Repeater & sensors**

**TO REDUCE THE RISK OF AN ELECTROSTATIC DISCHARGE (ESD) PLEASE TOUCH THE WHEEL WHEN SCREWING ON THE TIRE SENSOR ON TO THE TIRE VALVE. THIS IS TO MINIMIZE POTENTIAL ESD ATTACK WHICH MAY CAUSE DAMAGE TO THE TIRE SENSOR AND ITS FUNCTION.**

**INSTALLING FOBO ULTRA SETS ON MORE THAN ONE VEHICLE WHICH ARE PARKED CLOSELY TOGETHER MAY CAUSE CROSS INTERFERENCE TO THE BLUETOOTH SIGNALS. PLEASE INSTALL FOBO ULTRA ON ONE VEHICLE AT A TIME.**

To begin using FOBO Ultra, firstly ensure that the FOBO Ultra App is downloaded and you have already login to the App (see section 5.1 above for installation and login).

Follow the steps below to pair FOBO Ultra to your smartphone:-

- 1) Turn on your smartphone's Bluetooth connection.
- 2) Open FOBO Ultra App.
- 3) Open the battery cover and remove the battery tab to power up the InCar/Repeater unit (refer to page #38 for details).
- 4) Set the FOBO Ultra's In-Car unit/Repeater into 'pairing mode' by long press "SELECT" to start pairing.
- 5) Click on "+" (Top left for iOS (Refer to section 5.1.2) and Bottom right for Android (Refer to section 5.2.1) to create profile and to start pairing. Upon successful pairing with In-car unit Air-pair ID will appear on the smartphone in the Air-pair Box.

- 6) Key in the name you would like to identify your Vehicle. (Refer to section 5.1.5 (for iOS) & 5.2.4 (for Android).
- 7) Choose number of Axles. (Refer to section 5.1.5 (for iOS) & 5.2.4 (for Android).
- 8) Tap on the profile picture box and take a picture of your vehicle (Refer to section 5.1.5 (for iOS) & 5.2.4 (for Android).
- 9) Select the vehicle manufacturer recommended tire pressure (Refer to section 5.1.5 (for iOS) & 5.2.4 (for Android) for all the axles (Choose number of axles). The information is usually available on a sticker at the door jamb (side of the driver's door) or in the owner's manual. For certain vehicle models, the information sticker may be on the trunk lid or on the fuel door. You cannot proceed with the pairing without the input of this information into the FOBO Ultra App.
- 10) Click "Done" on the top right corner of the screen.
- 11) Upon successfully creating the profile on smartphone, Select "Installation" under Main Menu of In-Car unit and follow the instructions on screen of the In-Car unit.

**Note:** During installation of sensor, if sensor is not responsive, gently tap the sensor on the spot of "NFC logo" - 

- 12) You will be prompted that installation is completed and you are now ready to use FOBO Ultra.



### CAUTION:

Motor vehicles of all kinds (caravan, trucks, RV and Trucks) come with a very wide variety of rims, wheels, and tires, with an even larger choice of aftermarket products. It is impossible for us to test every combination and

check the fitment of the FOBO Ultra sensor. In some instances, when the FOBO sensor is screwed onto the valve stem, it might extend slightly beyond the face of the rim/wheel. If the rim/wheel comes close to or strikes an object, such as a curb, a pothole, the guide rail for an automatic vehicle wash, or a component on the vehicle, the FOBO sensor or the valve stem itself might become damaged. This can cause the FOBO to provide improper readings, or might cause a loss of air pressure. We recommend that you carefully assess the fitment of your rims, wheels, tires and the FOBO on your vehicle. If you have any concerns, consult with your tire shop or auto mechanic.

## 5.5 Sensor rotation

It is good practice to rotate your tire positions regularly to balance the thread wear of your tires, usually swapping the front tires with the rear tires. FOBO Ultra is designed to conveniently set the sensors to their correct tire position in the in-car unit after you have swapped your tires on your vehicle. You do not need to physically remove the sensors. To correct the position of the sensors in the in-car unit/Repeater, please select “Tire Rotation” under Main Menu on in-car unit/Repeater. You will be prompted by the in-car unit/Repeater to:

- 1) Select the sensor position to rotate. Move to the desired position to select the sensor by using the arrow key which is in the middle of the in-car unit/Repeater.
- 2) Upon selection, you will be prompted to touch the sensor at the in-car unit /Repeater NFC location - 
- 3) There will be a message to indicate successful registration of new position.
- 4) Choose NEXT to go to another tire position to rotate.
- 5) Choose END to complete the rotation process.

You are now ready to use FOBO Ultra with the new tire positions. You can perform tire rotation as often as you want.

## 5.6 Disable sensor and Replace new sensor

You may want to disable a sensor due to a missing sensor or damaged sensor or to install a replacement sensor. Disabling a missing or damaged sensor will remove future missing sensor alerts.

**To disable a tire sensor:-**

1. Go to Sensor Management in the Menu of In-Car/Repeater, select “Disable sensor”.
2. Select the tire position in the screen to disable.
3. Once disabled You will see “Sensor Disabled” message will appear on the screen. Take note that FOBO Ultra will stop monitoring the disabled sensor position.

#### **To install a replacement tire sensor:-**

1. Select “Replace sensor” under Sensor Management in the Menu of In-Car/Repeater.
2. Move to the desired position to assign a replacement sensor.
3. Select the tire position to replace.
4. You will be prompted to touch the sensor to the in-car unit.
5. Once replaced you will see “Sensor is successfully replaced...” Please mount the sensor to the physical tire position in accord with the screen message.

NOTE: You can only install a replacement sensor after the tire position has been “Disabled”. You can purchase replacement sensors online from [www.my-fobo.com](http://www.my-fobo.com).

## **5.7 Release (Total/Sensor)**

### Release Total System:

Before passing on your FOBO Ultra set to another user, you will have to release the Total system from your FOBO account. Select “Release (Total/sensor)” under Main Menu on in-car unit then “Release total system”.

Make sure your In-Car unit and smartphone are with you. You will be prompted with a message to “Select PROCEED to continue and concurrently, on the smartphone you need to long-press onto the profile that you want to release and follow the instruction on the phone App”. Upon selecting PROCEED the In-Car unit will connect to the smartphone to initiate the release process. You will hear an audible sound upon successful release and a “System Released” message will appear on in-car unit screen.

Do note that after you have done “Release Total System” the sensors are still paired to the InCar unit. To release all the paired sensors you need to follow the “Release Sensor” section below.

**Note:** Return InCar unit or Repeater unit together with all the sensors have to be released from the mobile app in order to claim for warranty.

#### Release Sensor:

You may want to release paired sensors prior to passing the sensors to another user or return the sensors for replacement purpose. Select “Release (Total/sensor)” under Main Menu on in-car unit and then select “Release sensor”. Follow the steps as indicated by the InCar unit.

**Note:** Return sensors have to be released in order to claim for warranty.

## 5.8 Tire Inflation/Deflation

To Inflate/Deflate the tire user just need to unscrew the sensor, inflate/deflate the tire then screw back the sensor on tire valve. Users do not need to release or disable the sensor.

## 5.9 Drop & Hook

FOBO Ultra System offers Drop & Hook for easy attachment to and detachment from the trailers of prime mover. It enables harvesting of sensor data by clusters of individual sensors and then transmits the data amongst inter-connected cluster to the In-Car unit. FOBO Ultra system can display up to 46 wheel positions with a combination of 1 In-Car + 1 Repeater cluster. For example, for a prime mover that hauls 1 trailer, FOBO Ultra allows 1 In-Car unit for the prime mover and 1 repeater unit for the Trailer. 1 In-Car unit can monitor up to a cluster of 22 sensors while Repeater unit can monitor up to a cluster of 24 sensors. Each Repeater unit can be independently controlled, programmed and monitored.

To HOOK a trailer:

1. Select “Drop & Hook” in the Main Menu of In-Car unit.
2. Select “Hook a trailer”.
3. Upon selecting, the in-car unit will scan for available trailers nearby in Bluetooth range.
4. List of available trailers will be displayed on the in-car unit screen.

5. Select the desired trailer from the list which you would like to Hook.
6. To confirm press “Yes”.
7. Once hooked you will see “Hook successful” message will appear on the screen.

To DROP a trailer:

1. Select “Drop & Hook” in the Main Menu of In-Car unit..
2. Select “Drop a trailer”.
3. List of *hooked* trailer will be displayed on the screen.
4. Select the desired trailer from the list which you would like to Drop.
5. To confirm press “Yes”.
6. Once dropped you will see “Drop successful” message will appear on the screen.

Note: To Drop a Trailer it’s not necessary for the repeater to be available. User can drop a trailer using in-car unit.

## 6 In-Car unit/Repeater audio & LED alerts

The In-Car/Repeater unit will produce different tones and LED flashes for different situations. For repetitive alerts, you can stop the alerts by long press the In-Car unit/Repeater button once, however LED will continue to flash until user solve the issue.

Wake up – unit will produce “two tones (High- low)”, this shows that In-Car unit is awake and operational.

Sleep – unit will produce “one long tone (Low)” once, No LED will blink. This shows In-Car/Repeater unit is going to sleep and not operational. In-Car/Repeater unit goes to sleep to conserve battery when vehicle is not moving for 15 minutes. However the sensors will still be operational 24x7 and continue to monitor and alert to your smartphone in case of flat tire.

**WARNING: FOBO Ultra IS A MONITORING DEVICE TO ALERTS THE USER WHEN IT DETECTS SIGNALS THAT IS OUT OF PRE-SET CONDITIONS BASED ON THE SETTING BY THE USER. THE USER OR DRIVER IS SOLELY RESPONSIBLE TO FIND OUT THE ACTUAL CONDITION OF THE TIRE AND TO ENSURE PROPER TIRE MAINTENANCE. FOBO Ultra IS NOT RESPONSIBLE FOR WRONG DIAGNOSTICS OR FALSE ALERTS THAT MAY CAUSE INCONVENIENCE.**

## Summary of alerts:

Sr No.	Alert type	Red LED	Amber LED	Audible tone	Display
1	InCar Unit Startup	One time on	One time on	2 tones (low-high) will occur once.	-
2	L1 (8% below or 25% above recommended tire pressure)	-	Constant on	5 tones (high) will occur once. Alert will re-occur when InCar unit wakes up, provided tire condition remains the same.	-
3	L2 (15% below or 35% above recommended tire pressure)	-	Constant on	3 times (high-low) tone will occur continuously every 5s. It can be cancelled by long press on LEFT button. It will stop if InCar unit enters sleep mode or measures data back to normal. Alert will re-occur when the InCar unit wakes up, provided tire condition remains the same.	-
4	L3 (25% below or 45% above recommended tire pressure)	-	Constant on	3 times (high-low) tone will occur continuously every 5s. It can be cancelled by long press on LEFT button. It will stop if InCar unit enters sleep mode or measures data back to normal. Alert will re-occur when the InCar unit wakes up, provided tire condition remains the same.	-
5	Low Battery (InCar)	1 blink every 5s	-	-	Pop up low battery message whenever the screen is turned on. User need to press "OK" to hide the message.
6	Low Battery (Sensor)	1 blink every 5s	-	-	In tire status page, battery level column, show "--V".
7	Missing Sensor	-	5 fast blink.	-	-
8	Missing Repeater	1 blink every 5s	-	-	Trailer body shows blinking in the Hooked Device Page.
9	Temperature	-	Constant on	2 beeps every 5s	-

## 7 Replacing Battery – Sensor, In-car & Repeater

### Sensor Battery Replacement:

The coin cell battery (CR2032) used in the FOBO Ultra sensors could last up to Twelve months based on normal operating condition. Operating in extreme cold or hot temperatures may reduce battery operating life for both the tire sensors and the In-Car unit.

You will receive an alert on the smartphone and In-Car unit/Repeater when the sensor or In-Car unit/Repeater battery levels are low. You will be alerted every time you start to drive your vehicle until the battery is replaced. It is advisable to change the battery once you receive this battery alert to ensure proper performance of FOBO Ultra. Do not wait until the battery is fully drained as it will cause FOBO Ultra to stop working properly.

To replace the battery of sensor unit, unscrew the top cover. Be careful not to damage the rubber gasket as it may affect water resistance of the sensor unit. Ensure the battery (CR2032) is inserted with the “+” sign facing up, away from the PCB.

### A) Correct Way to Insert Battery

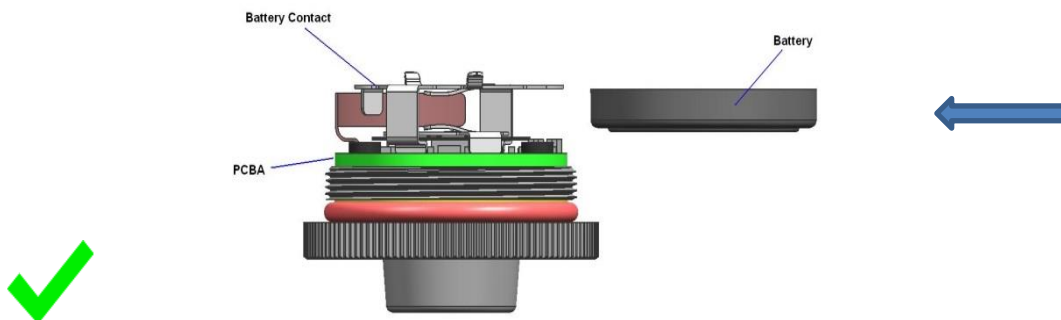



## **B) Incorrect Way to Insert Battery**

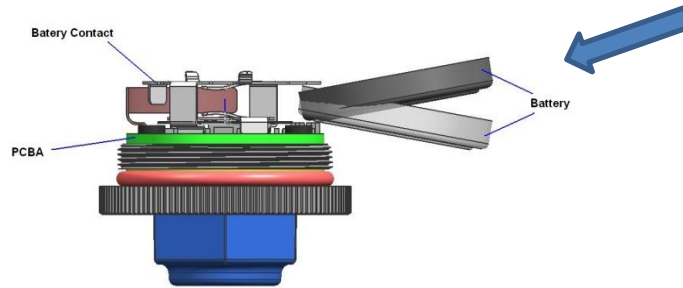

### **In-car unit Battery Replacement:**

To replace battery for the In-Car unit, open the battery cover and take out the battery pack. Ensure the battery (AA) is inserted in the correct orientation. It is advisable to use good quality AA batteries (recommended Lithium or Alkaline) for long lasting performance of In-Car unit.

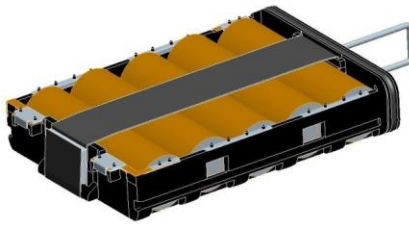
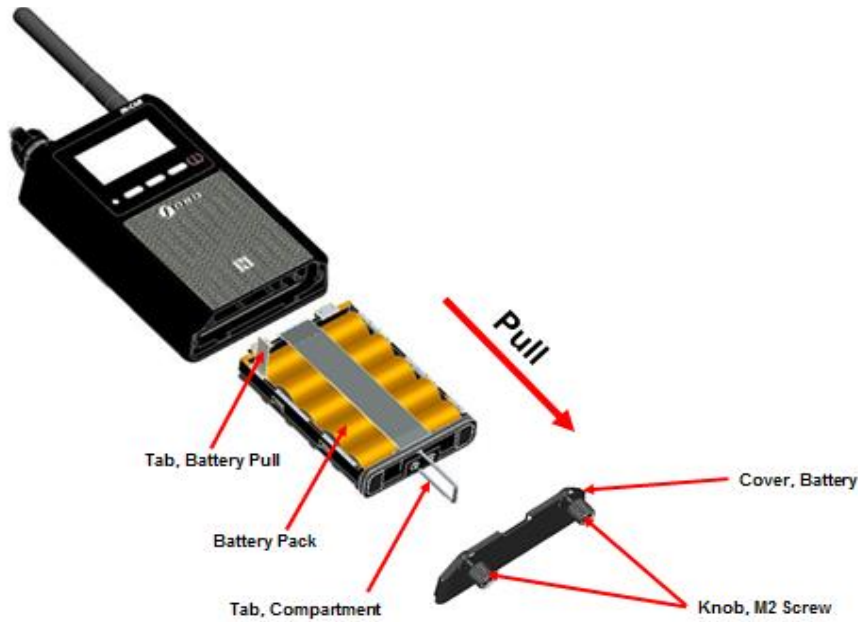

**Battery pack condition**

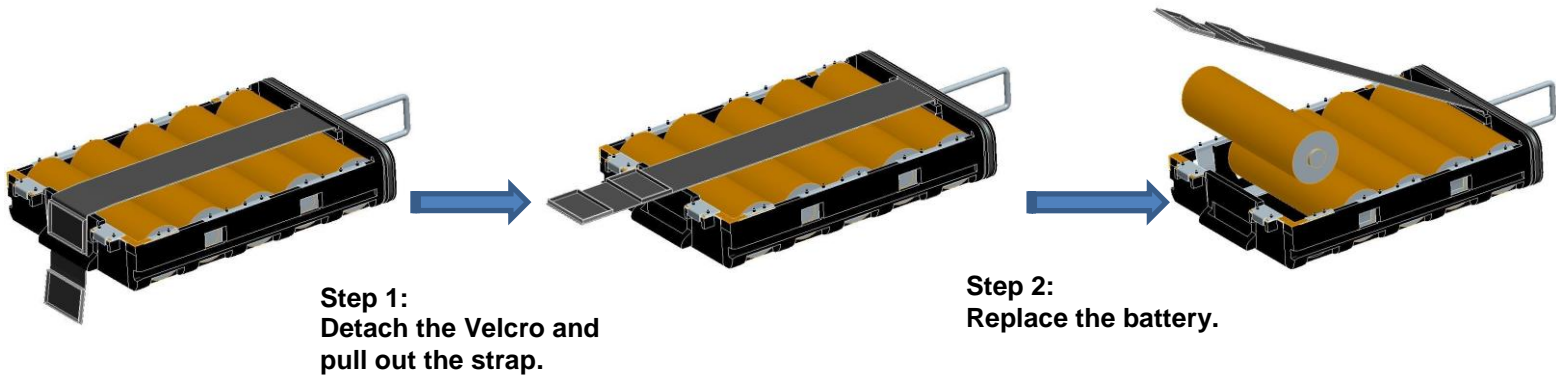

**Repeater Unit Battery replacement:**

To replace battery for the Repeater unit, open the battery cover and take out the battery pack. Ensure the battery (AA) is inserted in the correct orientation. It is advisable to use good quality AA batteries (recommended Lithium or Alkaline) for long lasting performance of In-Car unit. User does not need to remove the whole repeater unit while replacing the battery. Refer to the illustration below showing repeater unit battery replacement.

**Instructions:**

**Step 1: Unscrew both Knob, M2 Screws just until Cover, Battery can be remove**

**Step 2: Pull out the Tab, Compartment.**

**Step 3: Replace the batteries ( as shown below)**

**Step 4: Insert back battery pack followed by Cover Battery**

**Step 5: Tighten both two Knob, M2 Screws**

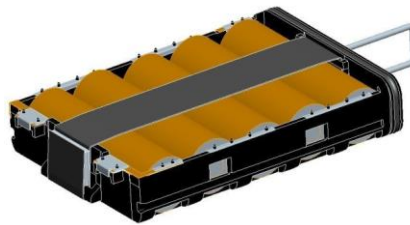
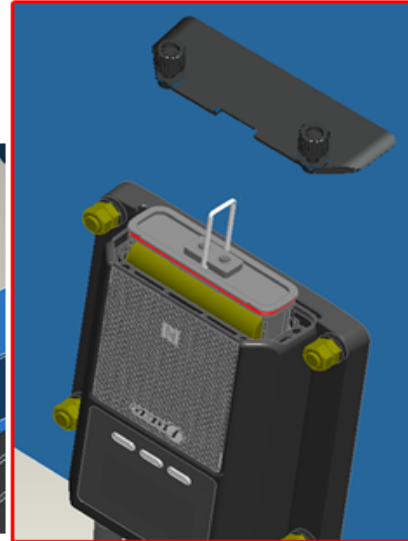
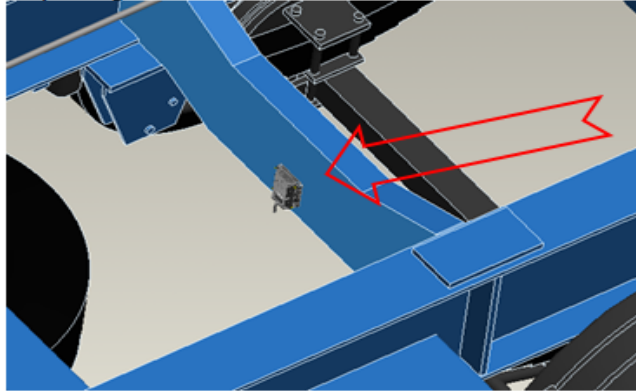

**Battery pack condition**

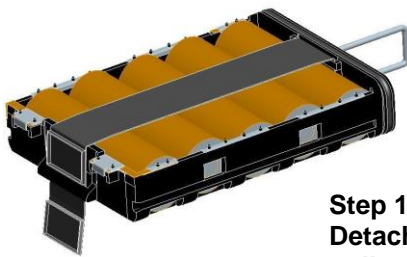

**Step 1:**  
Detach the Velcro and pull out the strap.

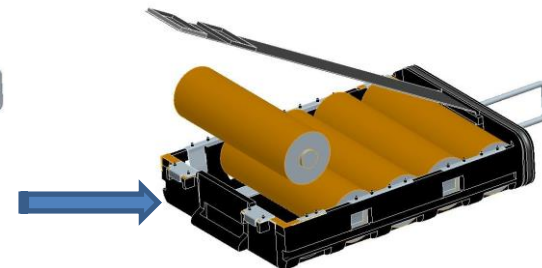
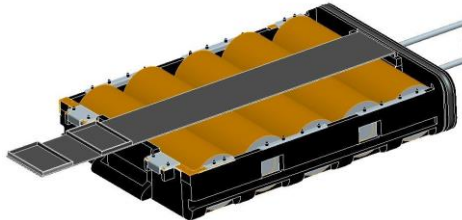

**Step 2:**  
Replace the battery.

**WARNING: RE-USING OLD BATTERIES OR MIXING OLD AND NEW BATTERIES IN THE IN-CAR UNIT MAY DAMAGE THE ELECTRONICS.**

## 8 Tire Changing Guideline

Precaution: Make sure the sensors are being mounted back onto the respective original tire position.

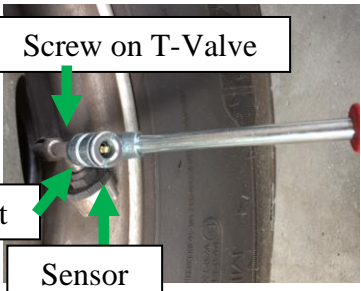
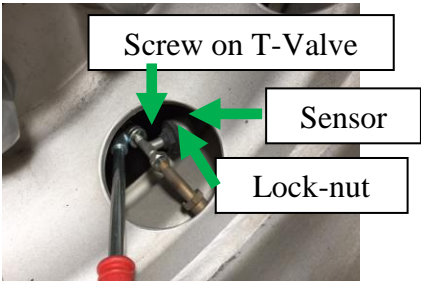
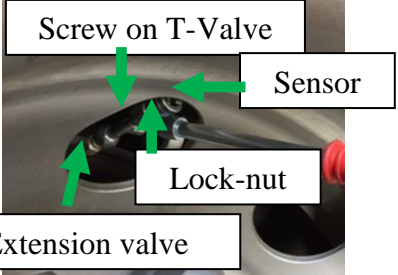
<b>Changing front tires</b>	
	<ol style="list-style-type: none"> <li>1. Loosen the lock-nut behind the sensor by turning it in the clockwise direction.</li> <li>2. Remove the sensor.</li> <li>3. Remove the lock-nut.</li> <li>4. Remove the screw-on T-valve.</li> <li>5. Take out the old tire and replace with new tire.</li> <li>6. Install back the screw-on T-valve and make sure it is sufficiently tight.</li> <li>7. Screw in the lock-nut.</li> <li>8. Screw in the sensor and tighten the lock-nut by turning it in the anticlockwise direction.</li> <li>9. As a final safeguard apply soap water to onto the tire valve stem/T-valve/sensor joints to check for potential air leak.</li> </ol>
<b>Changing rear outer tires</b>	
	<p>Same as changing front tires.</p>
<b>Changing rear inner tires</b>	
	<ol style="list-style-type: none"> <li>1. Loosen the lock-nut behind the sensor by turning it in the clockwise direction.</li> <li>2. Remove the sensor.</li> <li>3. Remove the lock-nut.</li> <li>4. Remove the screw-on T-valve.</li> <li>5. Remove the extension valve.</li> <li>6. Take out the old tire and replace with new tire.</li> <li>7. Screw in the extension valve and make sure it is sufficiently tight.</li> <li>8. Install back the screw-on T-valve and make sure it is sufficiently tight.</li> <li>9. Screw in the lock-nut.</li> <li>10. Screw in the sensor and tighten the lock-nut by turning it in the</li> </ol>

anticlockwise direction.

11. As a final safeguard apply soap water to onto the tire valve stem/extension valve/T-valve/sensor joints to check for potential air leak.

## 9 Troubleshooting Guide

- **Could not sign up a new FOBO account (did not receive activation e-mail)**
  - Check the e-mail address entry is typed correctly
  - Check the Spam mailbox, in case the e-mail was filtered by the e-mail server
  - Check the smartphone is connected to internet and able to receive e-mail
  
- **Could not sign up a new FOBO account (received activation e-mail)**
  - Make sure to click on the “Activation” link of the latest e-mail, in case there are multiple authentication e-mails
  - You should be directed to web page that clearly displayed “FOBO account is activated”.
  
- **Unable to Login after signing up to FOBO App**
  - Make sure your e-mail address is typed correctly
  - A verification mail will be sent to your e-mail address
  - Follow the instruction in the mail to activate your account before you can Login
  - Check if internet connection is available on your smartphone
  
- **Unable to pair FOBO Ultra In-Car unit/Repeater**
  - Make sure the battery is installed correctly and battery tab is removed.
  - Make sure your smartphone has Bluetooth 4.0 or later (Smart Ready) capability. **NOTE: BLUETOOTH 2.0 OR 3.0 WILL NOT WORK WITH THIS DEVICE.**
  - Please check if the FOBO Ultra has been paired before to another FOBO account. You’ll need to “Release” the FOBO Ultra set from the FOBO account that it is paired to, before using on your account. The FOBO Ultra is designed to pair with one FOBO account only for theft deterrent feature.

- Try to reset the Bluetooth manager of your smartphone (for iOS: Settings-> Bluetooth-> OFF->ON). At times the Bluetooth manager may be disrupted which may require manual reset.
- Try to do a hard reset on the phone.

- **What to do if in-car unit show Low signal/Missing for individual tire position with 5 fast blinks on Amber LED (on Right)?**

Firstly, driver need to find out the exact reason for this issue as this could be due to various reasons, such as:

1. Sensor Battery finished.
2. Sensor Missing ( Somebody steal the sensor or Flew off)
3. Sensor Damaged due to external force.
4. Sensor stopped working due to some internal issue.

**Driver need to follow the below troubleshooting steps:**

**First step**, look for physical presence of the sensor to ensure it is not related to 2<sup>nd</sup> reason (Sensor Missing (Somebody steal the sensor or Flew off)).

**Second step**, Look for any external damage on the sensor, if the sensor is externally damaged then driver need to disable the problematic tire position by using the in-car unit. Press Menu (Left button) on the in-car unit – go to sensor Management under Main Menu – select Disable sensor under sensor management – choose problematic tire position to disable.

Upon getting the new sensor, use replace sensor option under sensor management to install the new sensor.

**Third step**, Try by changing sensor battery to new to ensure it is not related to 1<sup>st</sup> reason (Sensor Battery finished), unscrew the sensor from tire valve – open the sensor cover – remove sensor battery – wait for 15 seconds – insert new battery – close back the sensor cover - screw back the sensor on tire valve.

- **What to do if in-car unit making noise with 3 high-low tone every 5 seconds with Amber LED continuous on?**

In-car unit will make such noise when the tire pressure is above (35% or 45%) or below (15% or 25%) the pre-set pressure limits. This type of alert is considered as an emergency alert and driver need to stop the vehicle if such alert occurs.

Driver need to stop the vehicle at some safe location and then press the center button on the in-car unit to check the problematic tire position, if the pressure

is very low then driver need to pump the air or fix the puncture to bring the tire pressure within the normal limit. If driver is unable to fix the tire then he can mute the alert by pressing the center button on in-car unit ( on screen showing alerts ) and then press mute on the extreme left corner. Alerts will reoccur once the vehicle ignition is switched off and on or in-car unit sleep and wake up provided the tire condition is still the same.

- **What to do if Red Led (On left) on the in-car unit blinks 1 time every 5 seconds?**

In car unit will show such blinks when any of the sensor battery is low. Driver need to Press Menu on In-car unit – Select Tire status page under Main menu – check for the tire position showing “—V” instead of battery readings.

Change the battery for problematic tire position, unscrew the problematic sensor from tire valve – open the sensor cover – remove sensor battery – wait for 15 seconds – insert new battery – close back the sensor cover - screw back the sensor on tire valve.



## 10 FOBO Ultra Specifications

### Sensor Specifications (Model - TU1602):

- Maximum Pressure 1296 Kpa (188 psi)
- Pressure Accuracy:
  - 1  $\sigma$  = +/- 0.79 psi (0 to + 50 °C)
  - 1  $\sigma$  = +/- 1.06 psi (-40 to + 85°C)
- Temperature Accuracy:
  - 1  $\sigma$  = +/- 1 °C (0 to + 50 °C)
  - 1  $\sigma$  = +1.33 / - 1°C (-40 to + 85°C)
- Operational temperature range: -40 to 85°C
- Up to 12 months battery life CR2032
- Dust protected & Waterproof : IP57
- Light weight sensors. Only 12.6 g each
- Certification: FCC, CE, BQB and RoHS
- Mechanical & Environmental Reliability Testing Standards: IEC 60068-2-2, IEC 60068-2-1, IEC 60068-2-29, IEC 60068-2-5, IEC 60068-2-32, ISO 15184, ISO 2409, SAE J2848 , SAE J1455
- Bluetooth 4.1 (Compatible with Bluetooth 4.0 or later)
- Compatible with iOS 7.1 or Android 4.3 or later.
- Input Rating : 3.0 Vdc, 30uA

### In-Car / Repeater Specifications (Model - TU1601):

- Operational temperature range: -40 to 85°C
- Battery life: up to 2 months when use as a sole source
- Power source: Battery AA x 5 pcs or 12V to 24V external supply
- Operating Temperature
  - With vehicle power source: -40°C ~ +85°C
  - With Alkaline batteries: -18°C ~ +50°C
- Storage Temperature:
  - Without Alkaline battery: -40°C ~ +85°C
  - With Alkaline battery: -30°C ~ +45°C
- Weight : 100g (without battery)
  - 220g with 5x alkaline batteries
- Dust protected & Waterproof : IP57 (Repeater only)
- Certification: FCC, CE, BQB and RoHS
- Mechanical & Environmental Reliability Testing Standards: IEC 60068-2-2, IEC 60068-2-1, IEC 60068-2-29, IEC 60068-2-5, IEC 60068-2-32, ISO 15184, ISO 2409, SAE J2848 , SAE J1455
- Bluetooth 4.1 (Compatible with Bluetooth 4.0 or later)
- Compatible with iOS 7.1 or Android 4.3 or later
- NFC
- Input Rating : 7.5Vdc or 12-24Vdc, 65mA

## 11 Warning

- Take note that FOBO Ultra is not meant to function as anti-accident or anti-injury device. FOBO Ultra is not a substitute for safe tire maintenance practices. Please take full responsibility of your own safety while driving. And continue to send your car for regular tire check and maintenance.
- Please take extra precaution to acoustics safety when operating the FOBO Ultra In-Car unit. Note that placing the FOBO Ultra In-Car unit beeper close to your ear may result in injury to the ear or permanent loss of hearing.
- You shall not use the FOBO Ultra in any unlawful way that violates any laws.
- Avoid exposing the FOBO Ultra In-Car unit and sensors to solvent, fire or extreme temperatures.
- FOBO Ultra may fail to function properly if the battery is below optimum level. Replace the battery immediately to continue enjoying full features of FOBO Ultra.

### CAUTION

**THERE MAY BE A RISK OF EXPLOSION IF BATTERY IS REPLACED BY AN INCORRECT TYPE. DISPOSE ALL USED BATTERIES PROPERLY.**

## 12 Regulatory Information

### **Federal Communication Commission Interference Statement**

This device (PTP-TU1601) complies with Part 15 of the FCC Rules. Operation is subject to the following two conditions: (1) This device may not cause harmful interference, and (2) this device must accept any interference received, including interference that may cause undesired operation.

This equipment has been tested and found to comply with the limits for a Class B digital device, pursuant to Part 15 of the FCC Rules. These limits are designed to provide reasonable protection against harmful interference in a residential installation. This equipment generates, uses and can radiate radio frequency energy and, if not installed and used in accordance with the instructions, may cause harmful interference to radio communications. However, there is no guarantee that interference will not occur in a particular installation. If this equipment does cause harmful interference to radio or television reception, which can be determined by turning the equipment off and on, the user is encouraged to try to correct the interference by one of the following measures:

- Reorient or relocate the receiving antenna.
- Increase the separation between the equipment and receiver.
- Connect the equipment into an outlet on a circuit different from that to which the receiver is connected.
- Consult the dealer or an experienced radio/TV technician for help.

FCC Caution: Any changes or modifications not expressly approved by the party responsible for compliance could void the user's authority to operate this equipment.

This transmitter must not be co-located or operating in conjunction with any other antenna or transmitter.

### **Radiation Exposure Statement:**

The product (PTP-TU1601) comply with the FCC portable RF exposure limit set forth for an uncontrolled environment and are safe for intended operation as described in this manual. The further RF exposure reduction can be achieved if the product can be kept as far as possible from the user body or set the device to lower output power if such function is available.

## **Industry Canada statement:**

This device (10617A-TU1601) complies with ISED's licence-exempt RSSs. Operation is subject to the following two conditions: (1) This device may not cause harmful interference, and (2) this device must accept any interference received, including interference that may cause undesired operation.

Le présent appareil est conforme aux CNR d'ISED applicables aux appareils radio exempts de licence. L'exploitation est autorisée aux deux conditions suivantes : (1) le dispositif ne doit pas produire de brouillage préjudiciable, et (2) ce dispositif doit accepter tout brouillage reçu, y compris un brouillage susceptible de provoquer un fonctionnement indésirable.

## **Radiation Exposure Statement:**

The product (10617A-TU1601) comply with the Canada portable RF exposure limit set forth for an uncontrolled environment and are safe for intended operation as described in this manual. The further RF exposure reduction can be achieved if the product can be kept as far as possible from the user body or set the device to lower output power if such function is available.

## **Déclaration d'exposition aux radiations:**

Le produit est conforme aux limites d'exposition pour les appareils portables RF pour les Etats-Unis et le Canada établies pour un environnement non contrôlé.

Le produit est sûr pour un fonctionnement tel que décrit dans ce manuel. La réduction aux expositions RF peut être augmentée si l'appareil peut être conservé aussi loin que possible du corps de l'utilisateur ou que le dispositif est réglé sur la puissance de sortie la plus faible si une telle fonction est disponible.

## **Federal Communication Commission Interference Statement**

This device (PTP-TU1602) complies with Part 15 of the FCC Rules. Operation is subject to the following two conditions: (1) This device may not cause harmful interference, and (2) this device must accept any

interference received, including interference that may cause undesired operation.

This equipment has been tested and found to comply with the limits for a Class B digital device, pursuant to Part 15 of the FCC Rules. These limits are designed to provide reasonable protection against harmful interference in a residential installation. This equipment generates, uses and can radiate radio frequency energy and, if not installed and used in accordance with the instructions, may cause harmful interference to radio communications. However, there is no guarantee that interference will not occur in a particular installation. If this equipment does cause harmful interference to radio or television reception, which can be determined by turning the equipment off and on, the user is encouraged to try to correct the interference by one of the following measures:

- Reorient or relocate the receiving antenna.
- Increase the separation between the equipment and receiver.
- Connect the equipment into an outlet on a circuit different from that to which the receiver is connected.
- Consult the dealer or an experienced radio/TV technician for help.

FCC Caution: Any changes or modifications not expressly approved by the party responsible for compliance could void the user's authority to operate this equipment.

This transmitter must not be co-located or operating in conjunction with any other antenna or transmitter.

### **Radiation Exposure Statement:**

This equipment (PTP-TU1602) complies with FCC radiation exposure limits set forth for an uncontrolled environment. This equipment should be installed and operated with minimum distance 20cm between the radiator & your body.

### **Industry Canada statement:**

This device (10617A-TU1602) complies with ISED's licence-exempt RSSs. Operation is subject to the following two conditions: (1) This device may not cause harmful interference, and (2) this device must accept any interference received, including interference that may cause undesired operation.

Le présent appareil est conforme aux CNR d' ISED applicables aux appareils radio exempts de licence. L'exploitation est autorisée aux deux conditions suivantes : (1) le dispositif ne doit pas produire de brouillage préjudiciable, et (2) ce dispositif doit accepter tout brouillage reçu, y compris un brouillage susceptible de provoquer un fonctionnement indésirable.

**Radiation Exposure Statement:**

This equipment (10617A-TU1602) complies with ISED radiation exposure limits set forth for an uncontrolled environment. This equipment should be installed and operated with minimum distance 20cm between the radiator & your body.

**Déclaration d'exposition aux radiations:**

Cet équipement est conforme aux limites d'exposition aux rayonnements ISED établies pour un environnement non contrôlé. Cet équipement doit être installé et utilisé avec un minimum de 20 cm de distance entre la source de rayonnement et votre corps.

**European Union Regulatory Conformance**

This equipment is CE marked according to the provisions of the R&TTE Directive (99/5/EC) and is in compliance with the essential requirements and other relevant provisions of the Directive 1999/5/EC. This equipment meets the following conformance standards:

EN 300 328, EN62479, EN 301 489-1&17, EN 60950-1

**EU Declaration of Conformity**

Hereby, Salutica Allied Solutions Sdn. Bhd. declares that this Bluetooth device is in compliance with the essential requirements and other relevant provision of Directive 1999/5/EC.

**Caution:** Changes or modifications to this **FOBO** device not expressly Approved by the party responsible for compliance could void the user's authority to operate it.

**Bluetooth Wireless Compatibility:**

This **FOBO** device supports the following Bluetooth wireless protocols and profiles:

- Bluetooth core technology v4.0
- Battery Profile (BAS)
- Proximity (PXP)
- Device Information Service (DIS)

**Bluetooth Wireless Interoperability:**

This **FOBO** device is designed to be interoperating with all Bluetooth wireless products that support compatible profiles and roles including:

- Bluetooth core technology v4.0
- Bluetooth master and slave roles

**NCC Statement [警語內容]****低功率電波輻射性電機管理辦法**

第十二條 經型式認證合格之低功率射頻電機，非經許可，公司、商號或使用者均不得擅自變更頻率、加大功率或變更原設計之特性及功能。

第十四條 低功率射頻電機之使用不得影響飛航安全及干擾合法通信；經發現有干擾現象時，應立即停用，並改善至無干擾時方得繼續使用。

前項合法通信，指依電信法規定作業之無線電通信。

低功率射頻電機須忍受合法通信或工業、科學及醫療用電波輻射性電機設備之干擾。

## 13 Intellectual Properties

- FOBO™ is a trademark of Salutica Allied Solutions Sdn Bhd. All rights reserved.
- FOBO™ Ultra incorporates a few patent pending technologies solely owned by Salutica Allied Solutions Sdn Bhd.

- Bluetooth<sup>®</sup> is a registered trademark owned by Bluetooth SIG Inc.
- iPhone<sup>®</sup> is a registered trademark of Apple Inc.

## **14 Limited Warranty & Disclaimer**

### **14.4 Warranty**

FOBO Ultra comes with a 12 months limited warranty. This Limited Warranty does not cover: 1) products purchased from an unauthorized reseller; 2) products purchased through online auctions; 3) products that are operated in combination with software, peripheral or ancillary equipment such as but not limited to batteries, chargers, adapters, headsets, connector cables, and power supplies ("Ancillary Equipment") not furnished or otherwise certified by Salutica for use with the FOBO products or any damage to the FOBO products or ancillary equipment as a result of such use; 4) damage caused by (a) accident, fire, misuse, neglect, unusual physical or electrical stress, or modification; (b) improper or unauthorized installation, wiring, repair, testing or (c) use of the product outside Salutica's published guidelines; 5) instances in which someone other than Salutica (or its authorized service centers) tests, alters, modifies or services the products in any way; 6) products that have (a) serial numbers or date tags that have been removed or altered, or (b) nonconforming or non-FOBO housings or parts; and 7) consumable spare parts and accessories (unless they are found to be non-functional or broken upon purchase of product).

In order to obtain any warranty service, you agree to bear all shipping charges of the FOBO Ultra device to Salutica's address.

### **14.5 Disclaimer**

SALUTICA MAKES NO OTHER EXPRESS WARRANTY WHETHER WRITTEN OR ORAL AND SALUTICA EXPRESSLY DISCLAIMS ALL WARRANTIES AND CONDITIONS NOT STATED IN THIS LIMITED WARRANTY. TO THE EXTENT ALLOWED BY THE LOCAL LAW OF JURISDICTIONS OUTSIDE MALAYSIA, SALUTICA DISCLAIMS ALL IMPLIED WARRANTIES OR CONDITIONS, INCLUDING ANY IMPLIED WARRANTIES OF MERCHANTABILITY AND FITNESS FOR A PARTICULAR PURPOSE. FOR ALL TRANSACTIONS OCCURRING IN MALAYSIA, ANY IMPLIED WARRANTY OR CONDITION OF MERCHANTABILITY, SATISFACTORY QUALITY, OR FITNESS FOR A PARTICULAR PURPOSE IS LIMITED TO THE WARRANTY PERIOD



AS PROVIDED BY SALUTICA IN THE MATERIALS RECEIVED AT THE TIME OF PURCHASE.

No warranty is made that the software provided by Salutica will meet your requirements or will work in combination with any hardware or Applications software products provided by third parties, that the operation of the software products will be uninterrupted or error free, or that all defects in the software products will be corrected.

### **14.6 Limitation of Liability**

THE MAXIMUM LIABILITY OF SALUTICA UNDER THIS LIMITED WARRANTY IS EXPRESSLY LIMITED TO THE LESSER OF THE PRICE YOU HAVE PAID FOR THE PRODUCT OR THE COST OF REPAIR OR REPLACEMENT OF THAT PRODUCT OR ANY COMPONENT OR PART THAT MALFUNCTION IN CONDITIONS OF NORMAL USE. EXCEPT AS INDICATED ABOVE, IN NO EVENT WILL SALUTICA BE LIABLE FOR ANY DAMAGES CAUSED BY THE FOBO ULTRA PRODUCT OR THE FAILURE OF THE PRODUCT TO PERFORM, INCLUDING ANY LOST PROFITS OR SAVINGS OR SPECIAL, INCIDENTAL, OR CONSEQUENTIAL DAMAGES. SALUTICA IS NOT LIABLE FOR ANY CLAIM MADE BY A THIRD PARTY OR MADE BY YOU FOR A THIRD PARTY. THIS LIMITATION OF LIABILITY APPLIES WHETHER DAMAGES ARE SOUGHT, OR A CLAIM MADE, UNDER THIS LIMITED WARRANTY OR AS A TORT CLAIM (INCLUDING NEGLIGENCE AND STRICT PRODUCT LIABILITY), A CONTRACT CLAIM, OR ANY OTHER CLAIM. THIS LIMITATION OF LIABILITY CANNOT BE WAIVED OR AMENDED BY ANY PERSON. THIS LIMITATION OF LIABILITY WILL BE EFFECTIVE EVEN IF YOU HAVE ADVISED SALUTICA OR AN AUTHORIZED REPRESENTATIVE OF SALUTICA OF THE POSSIBILITY OF ANY SUCH DAMAGES. THIS LIMITATION OF LIABILITY, HOWEVER, WILL NOT APPLY TO CLAIMS FOR PERSONAL INJURY.

### **14.7 What Law Governs This Warranty**

THIS LIMITED WARRANTY IS GOVERNED BY AND CONSTRUED UNDER THE LAWS OF MALAYSIA.