



FOBO Tire Plus

User Manual

Version 2.3

(For iOS7.1 and Android 4.30 & above)

Contents

- 1 Introduction**
- 2 About FOBO Tire Plus**
- 3 Importance of Tire Care**
- 4 Product Description of FOBO Tire Plus**
 - 4.1 In-Car unit**
 - 4.2 Tire Sensor unit**
 - 4.3 Sensor lock nuts & wrench**
- 5 Using FOBO Tire Plus**
 - 5.1 Installing FOBO Tire App**
 - 5.2 Installing FOBO Tire Plus In-Car unit and sensors**
 - 5.3 FOBO SHARE - Setting up multiple users, Pull/Push**
 - 5.4 Tire rotation**
 - 5.5 Disable sensor and Replace new sensor**
 - 5.6 Transfer FOBO Tire Plus to another user**
 - 5.7 Show/Hide Recommended Tire Pressure**
 - 5.8 Clear Memory**
 - 5.9 How to change Car profile picture**
 - 5.10 How to turn on Gage pressure**
 - 5.11 How to Turn on FoboSignal +**
 - 5.12 How to turn on Off Road Mode**
 - 5.13 Tire Inflation/Deflation**
 - 5.14 Reference pressure at 20 deg C**
 - 5.15 Overlay service**
 - 5.16 Sensor status in the App**
 - 5.17 Auto Night Mode**
- 6 FOBO Tire Plus Alert Messages**
- 7 In-Car unit audio & LED alerts**
- 8 Replacing Battery**
- 9 Trouble Shooting Guide**
- 10 FOBO Tire Plus Specifications**
- 11 Warning**
- 12 Regulatory Information**
- 13 Intellectual Properties**
- 14 Limited Warranty and Disclaimer**

1 Introduction

FOBO Tire Plus is the world's most advanced Tire Pressure Monitoring System (TPMS) using Bluetooth Smart (Bluetooth 4.0) technology to monitor your car tire pressure and temperature. Bluetooth Smart is a very low power wireless technology that could operate on a single coin cell battery for up to two years (**NOTE: Battery life may vary according to usage and climatic temperature. Operating under extreme cold may drastically reduce battery life.**)

Please ensure that your smartphone has Bluetooth Smart Ready (Bluetooth 4.0) capability in order to use FOBO Tire Plus. Currently FOBO Tire Plus works best with iOS7.1 and Android 4.30 and above.

Before starting to use FOBO Tire Plus, please download the free FOBO Tire App to your smartphone from Google PlayStore or Apple AppStore.

FOBO Tire Plus is a product designed and produced by Salutica Allied Solutions Sdn. Bhd. ("Salutica"), a Malaysian company with its address at No. 3, Jalan Zarib 6, Kawasan Perindustrian Zarib, 31500 Lahat, Ipoh, Perak, Malaysia.

2 About FOBO Tire Plus

FOBO Tire Plus monitors your car tires non-stop around the clock. Most drivers have encountered situations where they need to rush for an urgent Appointment only to be stranded by a flat tire. Conventional Tire Pressure Monitoring Systems (TPMS) could not alert you in advance because it stops operating as soon as the car ignition is switched-off. With FOBO Tire Plus, you will get an alert as soon as the tire pressure drops below a certain pre-set level, even when the car ignition is switched off as long as you are within Bluetooth range (~30m). This alert gives you time to get the flat tire fixed before you need to use it.

FOBO Tire Plus can monitor up to 19 cars on each smartphone. You can receive data from the tire pressure sensors from all your cars without switching on the ignition. FOBO Tire allows you to monitor your car tires conveniently any time you want. **NOTE: Under certain conditions the signals from FOBO Tire Plus sensors may be blocked by surrounding objects or structures. If this occurs, please move around the vehicle in order to capture signals from all the tire sensors.**

If you are sharing your car with family members or friends, you can allow others to use access your FOBO Tire Plus sensors through the FoboShare function. After adding them through FoboShare, family members or friends using your car will receive alerts and data from your FOBO Tire on their own smart phone immediately.

FOBO Tire Plus consists of 4 tire sensors and 1 In-Car unit. Replace your tire valve caps with the sensors and place the In-Car unit inside the car. The sensors will



measure tire pressure of each tire and transmit via Bluetooth to the In-Car unit and your smartphone. In case of any problem, the In-Car unit will produce alert sound to notify you a problem and an alert will also pop up on your smartphone if it is within Bluetooth range. The In-Car unit also comes with LEDs to show position of the problematic tire.

FOBO Tire Plus system requires a smartphone and App for installation. In addition to being able to view information regarding your car tire pressure and temperature, the FOBO Tire smartphone App will also produce an alert when your tire has a problem.

DISCLAIMER: FOBO TIRE PLUS IS NOT A DEVICE THAT PREVENTS ACCIDENTS. IT IS ALSO NOT A DEVICE THAT PREVENTS TIRES FROM BECOMING DEFLATED OR OVERINFLATED. FOBO TIRE PLUS IS NOT A SUBSTITUTE FOR SAFE TIRE MAINTENANCE PRACTICES. PLEASE CONTINUE TO TAKE PRECAUTIONARY MEASURES WHILE DRIVING AND TAKE FULL RESPONSIBILITY OF YOUR VEHICLE'S TIRE CONDITION TO ENSURE SAFETY WHILE DRIVING. YOU SHOULD CONTINUE TO PRACTICE PROPER TIRE CARE AND SCHEDULED TIRE MAINTENANCE.

3 Importance of tire care

It is extremely important to ensure car tires are properly inflated for safety while driving. However, many drivers tend to neglect proper tire care and maintenance. The car tires are the only contact points between the car and the road. The weight of the car and passengers are supported by the air pressure inside the tires. Improperly inflated car tires may cause serious accidents on the road.

When tires are underinflated, the additional rolling resistance may cause build up of heat which may lead to the de-lamination of the tire materials as well as damage to the tire's sidewall thus increasing the chances of a tire blow-out. Underinflated tires will also cause accelerated wear on the tire shoulders thereby causing uneven tire wear. Gas mileage will also be affected due to additional rolling resistance when driving with underinflated tires. You would also experience a significant loss of steering precision and cornering stability. Significantly under-inflated tires will also be less effective in resisting hydroplaning.

On the other hand, an overinflated tire will cause accelerated wear on the center portion of the tire resulting in uneven tire wear. It would also result in a harsher ride and makes the tire more susceptible to damage when going over potholes or debris on the road.

What is the optimum tire pressure? There are a lot of information about this subject in internet forums and web articles. A quick guide for better understanding of tire pressure below:-

- 1) Car manufacturers recommend the optimum tire pressure for their car models. The information is usually available on a sticker at the door jam (side of the driver's door) or in the owner's manual. For some car models, the information sticker may be on the trunk lid or on the fuel door. Car manufacturers usually recommend different tire pressure for front and rear tires. This pressure is usually recommended for comfort driving and optimum performance of the car. It is not advisable to go below this recommended pressure level.
- 2) The car manufacturer recommended tire pressure is "cold pressure". When you drive your car to the gas station, the friction on the road will heat up your car tires within a few minutes. Typically there will 1 psi (~7kPa) increase in air pressure for every 10 deg F (5.6 deg C) rise in temperature. It is advisable to inflate the tire pressure with this compensated pressure above the recommended pressure.
- 3) Air pressure in tires is affected by changes in temperature. Check and adjust your tire pressure whenever there is a drastic change in environment temperature, eg. change of season.
- 4) A tire will normally lose its pressure through natural causes unless accelerated by a puncture, faulty valve or damaged wheels. It is advisable to change the tire valves or at least check the valves condition every time you change a new set of tires. Under normal condition, a set of tires could deflate at a rate of up to 2psi per month. It is good practice to check your tire pressure regularly and top up to the optimum pressure.
- 5) Every car tire has a maximum inflation pressure. It is not advisable to inflate to the maximum inflation pressure of the tire. Follow the car manufacturer's recommended tire pressure instead.

4 Product Description of FOBO Tire Plus

4.1 In-Car Unit

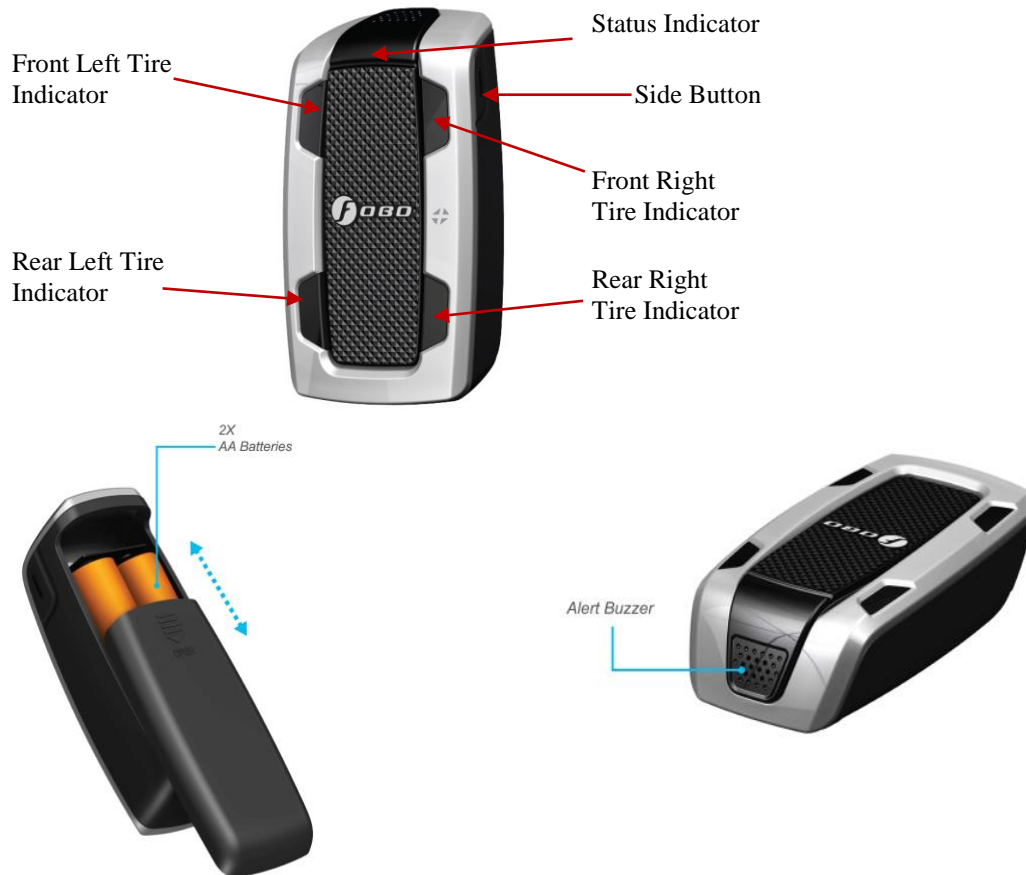

Tire position indicators

– To indicate which tire has problem

Side button

- **In normal condition:** A quick press on the side button to check the status of In-Car unit whether it is sleeping or in operational mode.

During tire alert: When there is a tire alert, a quick press on the side button to silent the alert. After silencing the alert, a quick press again will reproduce the tire alert once.

Synchronizing with smartphone: A long press on the side button to sync user settings with the smartphone. Similar a long press on the side button is also used during releasing of In-Car unit and pairing the unit.

NOTE: Excessive frequent pressing on the side button will drain the In-Car unit battery.



- | | |
|------------------|---|
| Status indicator | - LED will blink to show Bluetooth pairing mode or battery low status |
| Alert buzzer | - buzzer to alert when there is problem with tire |
| AA batteries | - In car unit operates with two AA size batteries. The batteries will work for up to two years. |

NOTE: For iOS user, please select “Allow” location services for FOBO Tire App when prompted by the OS. Without location services, the FOBO Tire App will not be able to sync with In-Car unit.

The FOBO Tire Plus In-Car unit is a complex device that performs multiple functions. Due to the shielding effect of the car chassis, some drivers may face difficulty in receiving the tire sensor signals on their smartphone when sitting inside the car. This problem may be further aggravated when the driver places the smartphone in positions that are not optimal such as trouser pocket or waist pouch. The In-Car unit is designed with an efficient antenna that can pick up sensor signals up to 10dB better than a usual smartphone. With the In-Car unit, you can be assured of a good signal reception from the tire sensors.

The In-Car unit is designed to be placed anywhere inside the car, please do not remove it from the car. In order for FOBO Tire Plus to functions optimally, please ensure that the In-Car unit remains inside the car. Note that In-Car unit is not water-proof. The best location to place the In-Car unit will be to affix it on the lower dashboard position but away from direct sunlight. Use the Velcro double side tape provided in the packaging to secure the In-Car unit. Do not enclose the In-Car unit inside any metal compartment or box. This will cause the In-Car unit unable to receive signals from tire sensors.

To conserve battery life, the In-Car unit will go into ‘sleep’ mode after it detects that the vehicle has been stationary for more than 15 minutes. It will ‘wake up’ once it detects that the vehicle moves. You can still receive your tire pressure and temperature data by accessing the FOBO Tire App on the smartphone, even when the In-Car unit is asleep. This is due to FOBO Tire Plus’s sensors continuous operation of 24 x 7 which allows you to receive an alert even when you are not driving the car.

The In-Car unit will also synchronize with your smartphone with your settings that you have changed every time it wakes up. For any changed settings in the App, it will only be synchronized during the next In-Car unit wake up cycle. Alternatively you can long press on the side button of In-Car unit until you hear a beep, in order to put the In-Car unit into synchronization mode with the smartphone App.

The In-Car unit is also designed to be a secondary alert device in the event of a deflated tire. This is to cover situations when you do not have your smartphone with you while driving or if your smartphone’s battery is dead. When there is a tire

pressure alert, the In-Car unit will produce an audible and visual LED alerts to inform you of a tire pressure problem. To silence the repetitive audio alerts, just quick press the side button once. To check back the position of the problematic tire, a quick press on the side button once more and the LED of the problematic tire position will light up.

The In-Car unit will emit a start-up tone every time it wakes up upon detecting the car's movement. This tone is also to inform you or the driver that the In-Car unit is operational. In case you do not hear this tone when start moving the car, please check the state of the In-Car unit by a quick press on the side button once. If you hear a long single tone that means the In-Car is still in sleep mode. You can change the detection sensitivity in the FOBO Tire App by going to Edit Car Profile -> Advance Setting screen to adjust the In-Car unit sensitivity. In some electric cars, the In-Car unit may require higher sensitivity to detect the car moving.

NOTE: Unnecessarily waking up the In-Car unit will drain battery.

4.2 Tire Sensor Unit



- | | |
|-------------------------|---|
| Knob cover | - waterproof cover. Please ensure the red silicon ring is intact to prevent water from getting into electronics compartment. |
| Single internal battery | - CR2032 coin cell battery. When replacing battery, please ensure the “+” sign of the battery is facing up, away from PCB. |
| Internal PCB | - internal electronics circuit (The pressure sensor chip is mounted within this PCBA, and it senses the tire pressure against a built-in vacuum, resulting in an Absolute Pressure reading. The internal firmware |



will then subtract the sea-level pressure of 101.3 Kpa (14.7 psi) from this reading. This final reading which will be shown in the app can be termed as i) **Tire Absolute Pressure minus sea level pressure**, or ii) Gage Pressure reference to sea-level altitude. With this formulation, Fobo tire sensor will read the same pressure value for any given tire, irrespective of altitude (assuming a constant temperature). This will ensure the correct tire footprint per vehicle manufacturer's pressure recommendation, for all altitude above sea-level, given a constant temperature.

As a corollary, a tire with a Fobo reading of, say 40 psi at an altitude of 5000ft, will read the same 40 psi when driven to sea-level, given a constant temperature. In reality, it will read higher due to the warmer temperature at sea-level, and may need some air release if the temperature difference is great. Tire pressure generally will increase 1 psi (~7kPa) for every 10 deg F (5.6 deg C) rise in temperature.

Fobo wishes to highlight the above formulation is for usage at sea-level and above, and will not be accurate for use otherwise. In practice, this should not be an issue as the lowest area on earth will result in an insignificant error of 0.3 psi (~2 Kpa).

For users who wish to retain 'Gage Pressure Reading', the Fobo Tire App has a Gage Pressure, adjusted to local altitude using cell towers or individual phone barometer if available. This Gage Pressure button can be accessed from the App (Kindly refers to Section 5.10 of this user manual).

FOBO Tire Plus sensor units are designed to be robust and operate reliably 24x7 to provide tire information around the clock. It is designed to be water proof (IP57) and by our special use of custom engineering plastics, it will be able to withstand road salts or other common automotive chemicals (petrol, engine oil, car wash shampoo, etc.).

Our designers have designed the sensors to ensure that there is no air leakage as it replaces the tire's original valve cap. There is no need to screw on the sensor extremely tight. Apply a reasonable hand twist force to ensure the sensor is securely installed and should be able to be removed by hand with ease.



When installing the sensors, please follow the on-screen prompt of the FOBO Tire App. Do not screw on the tire sensors until instructed by the FOBO Tire App. After installation, in the event the tire sensors positions are mixed up, usually after performing a tire rotation maintenance, you can easily reposition the sensors to their correct position by selecting 'Rotate Tires' on the FOBO Tire Plus App and follow the on-screen instructions. This eliminates the need to remove the tire sensors physically.

A missing or damaged tire sensor can be replaced easily through the FOBO Tire App. You will need to purchase a replacement sensor which you can do so online at www.my-fobo.com. To replace the sensor, first select 'Disable/Install Sensor' on the FOBO Tire App on your car status settings and the App will prompt you to tap on the tire position that you want to replace for 5 seconds. The box will then show "Disabled". Then, select 'Disable/Install Sensor' again and tap on the same box and the App will prompt you to install the replacement sensor. Follow the on-screen instruction and the replacement sensor will be paired and be ready to use.

NOTE: Battery life span up to Two years is an estimate based on normal use at 23 °C. Battery life may vary according to usage and climatic temperature.

Battery life span will change due to the following reasons:

- 1) Frequent change of pressure threshold setting in the App.
- 2) Disabling & enabling of sensors.
- 3) Release & pairing.
- 4) Removal & screw-on of sensors.
- 5) Operating under extreme cold/hot temperature.
- 6) Testing of product.
- 7) Rotation (refer section 5.4 of this user manual)
- 8) Trigger alert or let activated alerts unattended.
- 9) Multiple removal and screw-on of sensors for equalizing all tire pressures.

All these activities will drain a battery very fast and affect the battery life span.

4.3 Sensor Lock nuts and wrench



FOBO Tire Plus sensors and In-Car unit are tied to a FOBO account after installation. They are not re-usable or transferable without the owner releasing them from his/her FOBO account. This is a theft deterrent feature to discourage theft.

As an additional anti-theft feature, all FOBO Tire Plus package comes with lock-nuts and special wrench. FOBO Tire Plus's functionality is not affected if you do not use the lock-nuts.

The lock nuts and wrench are made of custom engineering plastics that can withstand road salts and common automotive chemicals (gasoline, engine oil, car wash shampoo, etc).

In order to use the lock nuts, you must first install the lock nut to the tire valve (with the bump facing tire rim). Screw in the lock nut all the way down and ensure that there is still a **minimum of 5 thread count** on the tire valve for the sensor unit to be screwed on. If there is insufficient thread for the tire sensor, it may lead to air leakage. A solution for this would be to change the tire valve to one with a longer thread. Next, screw in the tire sensor unit until it is reasonably tight. Then use your finger to unscrew the lock nut outwards (i.e. anti-clockwise) until it pushes against the bottom of the sensor unit. Use the wrench to tighten the lock nut. The resultant friction force will make it difficult to remove the sensor unit without loosening the lock nut. For rubber valves, hold the valve stem with one hand and tighten the lock nut with the wrench on another hand. This is to avoid the rubber valve from twisting making it unable to tighten the lock nut.

WARNING: Do not apply too much force to tighten the lock-nut. You may face difficulty to loosen the lock nut later on especially for rubber valves that typically doesn't stay firm on the tire rims.



NOTE: If your tire valve is too short, you shouldn't use the lock nut as this will block the sensors from being completely screwed on the tire valve and causes air leak. Our sensors are designed to work on a tire valve with a minimum of 5 thread counts.

Use the key chain provided to keep the wrench together with your car keys, so that you don't have to worry about misplaced wrench when you need to remove the sensors when adding air to your tires.

Step by step diagram to use FOBO Tire Plus Lock Nut and wrench

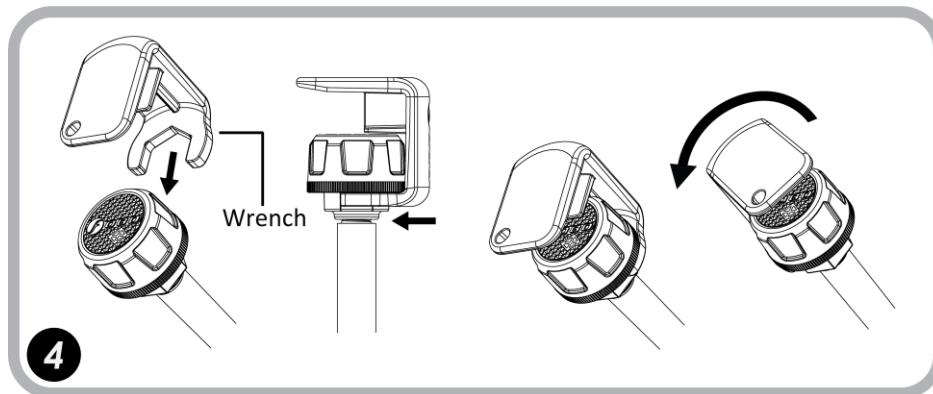
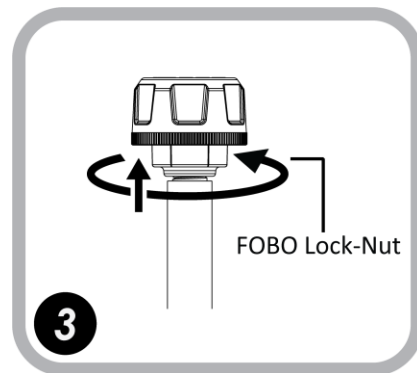
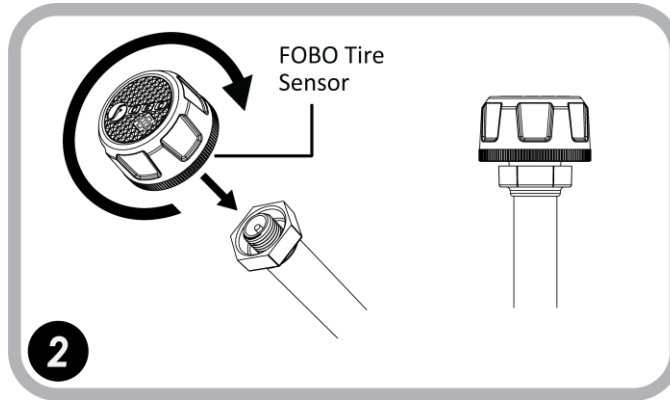
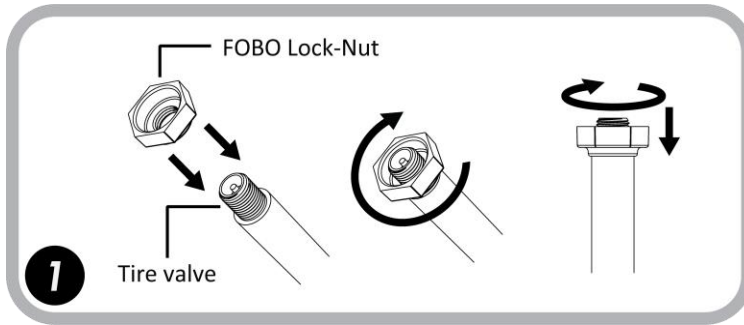

5 Using FOBO Tire Plus

5.1 Installing FOBO Tire App

You are required to have a smartphone with **Bluetooth 4.0** (Bluetooth Smart) capability in order to use FOBO Tire Plus. The smartphone must also be running on iOS 7.1 or Android 4.3 and above. Follow the steps below to install your FOBO Tire Plus:

Step 1: Download the FOBO Tire App onto your smartphone

- For iPhone users, download from Apple's AppStore. For Android users, download from GooglePlay. Search for "FOBO Tire". Note: FOBO Tire Plus uses the same App as FOBO Tire.

Step 2: Launch the FOBO Tire App & key in your email address

- For new users, key in your email address and click login.
- You will receive an email from FOBO with an activation link.
- Click on the activation link that you receive in your email.
- Once activated, go back to the FOBO Tire App and click on login again.
- You be brought to the App's Home screen.

Note:-

- An activation e-mail message will be sent to your e-mail address when you click on login as a first time user.
- If you do not receive this activation e-mail from FOBO Admin, please check your e-mail address entry to ensure it is valid without typo error.
- This e-mail may also be filtered by some e-mail servers. Please check your Spam mailbox.
- If you still do not receive any message from FOBO Admin after 15 minutes (with a good internet connection), please write in to fobo@salutica.com.my with your sign-in email.

IMPORTANT:

The email activation is to ensure that your account signup is done securely. FOBO Tire Plus is locked to your FOBO account as an anti-theft deterrent. Stolen sensors cannot be used by anyone else other than the FOBO account owner.

Location service is required to be enabled for the FOBO Tire App (FOBO Tire does not use the GPS function to track your location). The location service on the iOS/Android system has other functionality that the FOBO Tire App uses to operate properly and to sync with the In-Car



unit. It will ensure FOBO Tire Plus functions as designed, mainly for alert functions, and also the gauge pressure feature as required by users living at high altitudes. FOBO Tire is designed to be a low energy system and does not drain your smartphone battery excessively.

By submitting your information to sign up a new user account, you acknowledge your acceptance to the terms and conditions of our Software Licensing Agreement and Privacy Policy.

5.2 Installing FOBO Tire Plus In-Car unit & sensors

NOTE: DO NOT INSTALL THE SENSORS TO THE CAR TIRE VALVES UNTIL PROMPTED BY THE FOBO TIRE APP INSTRUCTION.

TO REDUCE THE RISK OF AN ELECTROSTATIC DISCHARGE (ESD) PLEASE TOUCH THE WHEEL WHEN SCREWING ON THE TIRE SENSOR ON TO THE TIRE VALVE. THIS IS TO MINIMIZE POTENTIAL ESD ATTACK WHICH MAY CAUSE DAMAGE TO THE TIRE SENSOR AND ITS FUNCTION.

INSTALLING FOBO TIRE PLUS SETS ON MORE THAN ONE CAR WHICH ARE PARKED CLOSELY TOGETHER MAY CAUSE CROSS INTERFERENCE TO THE BLUETOOTH SIGNALS. PLEASE INSTALL FOBO TIRE PLUS ON ONE CAR AT A TIME.

To begin using FOBO Tire Plus, firstly ensure that the FOBO Tire App is downloaded and you have already login to the App (see section 5.1 above for installation and login).

Follow the steps below to pair FOBO Tire Plus to your smartphone:-

- 1) Turn on your smartphone's Bluetooth connection.
- 2) Set the FOBO Tire Plus's In-Car unit into 'pairing mode'.
 - For new sets, remove the battery tab from In-Car unit battery compartment. This will put it into 'pairing' mode.
 - For used sets, long press on the In-Car unit button until you hear a beeping sound and the LED on the In-Car unit flashes to put it into 'pairing mode'. (Note: if an In-Car unit has its plastic tab taken out from the battery compartment before, install it as though it is a used set)
- 3) Open the FOBO Tire App.

- 4) Click on the “+” sign on the FOBO Tire App HOME screen to add a car to your profile.
- 5) The text box for the In-Car unit ID will be automatically filled a unique ID number.
- 6) Key in the name you would like to identify your car
- 7) Tap on the profile picture box and take a picture of your car.
- 8) Select the car manufacturer recommended tire pressure for the front and rear tires. The information is usually available on a sticker at the door jam (side of the driver’s door) or in the owner’s manual. For certain car models, the information sticker may be on the trunk lid or on the fuel door. You cannot proceed with the pairing without the input of this information into the FOBO Tire App.
- 9) Click “Done” on the top right hand corner of the screen.
- 10) Next, you will be prompted to install the tire sensors starting from the Front-Right tire.
- 11) Screw on the FOBO Tire Plus sensor to your Front-Right tire. Make sure your smartphone touches the sensor to pair the tire sensor unit. If you had screwed on the sensor before instructed by the App, remove the sensor completely, wait for 8 seconds and then screw it back in again. Repeat with the Rear-Right, Rear-Left and Front-Left tires as prompted by the App.
- 12) You will be prompted that installation is completed and you are now ready to use FOBO Tire Plus.



CAUTION:

Motor vehicles of all kinds (cars, trucks, motor scooters and motorcycles) come with a very wide array of rims, wheels, and tires, with an even larger choice of aftermarket products. It is impossible for us to test every combination and check the fitment of the FOBO sensor. In some instances, when the FOBO sensor is screwed onto the valve stem, it might extend slightly beyond the face of the rim/wheel. If the rim/wheel comes close to or strikes an object, such as a curb, a pothole, the guide rail for an automatic car wash, or a component on the vehicle (such as the brake system on a



motorcycle), the FOBO sensor or the valve stem itself might become damaged. This can cause the FOBO to provide improper readings, or might cause a loss of air pressure. We recommend that you carefully assess the fitment of your rims, wheels, tires and the FOBO on your vehicle. If you have any concerns, consult with your tire shop or auto mechanic. A shorter valve stem might be considered to mitigate the situation.

5.3 FOBO SHARE- Setting up multiple users

FOBO Tire Plus is easy to share with your family members and friends. You can share FOBO Tire Plus with up to 100 users by using the App's FoboShare function. All that is required is for the other person to download the FOBO Tire App (they will also need an iOS/Android smartphone with Bluetooth 4.0 that is running on iOS7.1 or Android 4.3 and above). They need to activate their App with their email and login to the App.

Follow these steps to share your FOBO Tire with other users:-

1. Ensure that the user receiving the sharing (recipient) has downloaded the FOBO Tire App and has activated their App with their own email address.
2. Ensure that the recipient's smartphone has their Bluetooth connection turned on.
3. On your car status screen, click on the settings icon and select 'FoboShare'.
4. Click on the "+" sign at the top right corner of the App.
5. Type in the recipient's email that was used to activate their App.
6. Your car profile will appear on the recipient's App with a "FoboShare" logo.
7. The recipient clicks on your car profile and he will start to receive all the data from the FOBO Tire Plus sensors on his smartphone when he is within Bluetooth range.

NOTE: Please ensure good internet connection for FOBO Tire App to connect to the cloud.

Note that shared users will not be able to change settings (name, user limits, etc) on your FOBO Tire Plus set. They can only view the readings and receive alerts. At the FOBO Tire's App HOME page, a shared car will depict a "FoboShare" logo at the bottom of car profile image to distinguish a shared car from your own car.

FOBO SHARE - Pull/Push feature

a) FOBO Share Pull/Push feature enables the FOBO Tire owner to pull on-demand the status of tires from the sharer. Likewise, the sharer can also push to the owner the status. The owner will also receive alerts concurrently as the sharer through internet, even when the car is being used by the sharer.

Note: For this new feature, there is a must to have a strong internet connection at both parties, Owner and Sharer.

b) To pull the latest readings from the sharer, at the “car status screen”, click at Setting at the top right corner. Select FOBO share and click at the email address of the sharer from the share list. At the pop-up menu, select “Pull car data from shared vehicle”.

Note: Upon clicking the “Pull car data from the shared vehicle”, the subsequent request can only be done after an interval of 300 seconds.

c) As a sharer to push the latest status to the owner, click at Setting at the top right corner of the car status screen, select “Push data to Owner”

Note: Once the Sharer clicks on the “Push data to Owner”, the subsequent request can only be done after an interval of 300 seconds

5.4 Tire rotation

It is good practice to rotate your tire positions regularly to balance the thread wear of your tires, usually swapping the front tires with the rear tires. FOBO Tire Plus is designed to conveniently set the sensors to their correct tire position in the App after you have swap your tires on your car. You do not need to physically remove the sensors. To correct the position of the sensors in the FOBO Tire App, please select Tire Rotation in car status screen. You will be prompted by the App to:

- 1) Move to the Front-Right tire of your car
- 2) Place your phone touching the sensor and hold it there for 15 seconds.
- 3) Repeat step 1 & 2 for the Rear-Right, Rear-Left and Front-Left tires.

You are now ready to use FOBO Tire Plus with the new tire positions. You can perform tire rotation as often as you want.

5.5 Disable sensor and Replace new sensor

You may want to disable a sensor due to a missing sensor or damaged sensor and to install a replacement sensor. Disabling a missing or damaged sensor will remove future missing sensor alerts.

To disable a tire sensor:-

1. Select “Disable/Install Sensor” at the car status screen setting.
2. Tap and hold on the box corresponding to the tire position you want to disable for 5 seconds.
3. Click OK on the message box to disable the sensor.
4. You will see “Disabled” inside the box corresponding to the disabled tire position. Take note that FOBO Tire Plus will stop monitoring tire for a disabled sensor position.

To install a replacement tire sensor:-

1. Select “Disable/Install Sensor” at the car status screen setting.
2. Tap and hold on the box corresponding to the tire position you want to install for 5 seconds. This would be the box with the text “Disabled” for the sensor that you had previously disabled.
3. Click OK on the message box to install the sensor. You will be prompted to screw on the sensor to the tire valve and hold your smartphone touching the sensor.
4. You will be prompted that the sensor has been successfully installed and you can immediately use it.

NOTE: You can only install a replacement sensor after the tire position has been “Disabled”. You can purchase replacement sensors online from www.my-fobo.com.

5.6 Transfer FOBO Tire Plus to another user

Before passing on your FOBO Tire Plus set to another user, you will have to release the In-Car unit from your FOBO account. Select “Release In-Car unit” from the car status screen setting. Make sure your In-Car unit is with you. You will be prompted with a message to press and hold the button at the side of In-Car unit until you hear a “Beep” sound and the car profile from your “Home” page is erased. Your FOBO Tire Plus set is now available for the other user to pair and use.

In case you do not hear a “Beep” after more than one minute, you may remove the batteries from back of In-Car unit and re-insert the batteries to reset the unit. Then select “Release In-Car unit” and repeat the procedure in above paragraph.

5.7 Show/Hide Recommended Tire Pressure

You can choose to display or hide the Vehicle Recommended Pressure for Front Tires (FRP) and Rear Tires (RRP) in the “Car Status” Page by selecting ‘Show Pressure Setting’ or ‘Hide Pressure Setting’ from the car status screen setting.

5.8 Clear Memory

The most recent tire pressure reading will be displayed in the “Car Status” screen whenever the phone and FOBO Tire Plus are within Bluetooth range. This pressure readings will be always be displayed as memory until the phone receives the next pressure reading update from FOBO Tire Plus sensors/In-Car Unit.

User can clear the memory of Tire Pressure readings by selecting Clear Memory option in the car setting screen. All four tire boxes will be in the “Car Status” Page will be cleared and display “--” until the phone receives signal from FOBO Tire Plus sensors/In-Car Unit.

This function is normally used for trouble shooting purposes. FOBO Tire Plus will always update the reading displayed on the App automatically with the latest reading. You do not need to select ‘Clear Memory’ to get the latest reading.

5.9 How to change Car profile picture

- Long press on the default car image, you will see a pop-up menu with 3 options:
 1. Image from camera.
 2. Image from library.
 3. FOBO image.
- Select your preferred option.

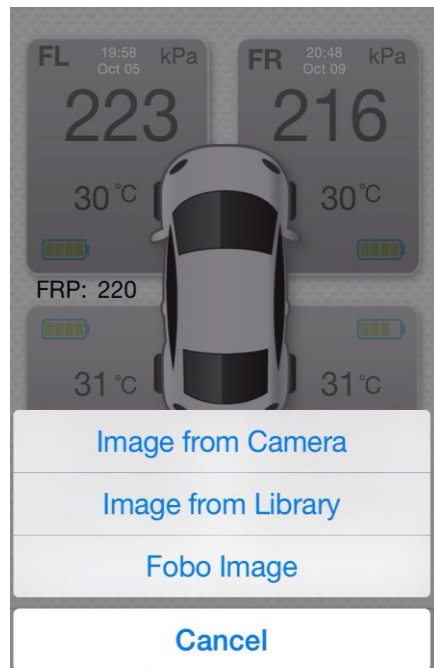

5.10 How to turn on Gage pressure

To turn on Gage pressure:-

- i. At the Car Status screen, click the gear icon at the top Right and select “Edit car Profile”.
- ii. Click at Advance Setting.
- iii. Turn on the Gage pressure by swiping the button.

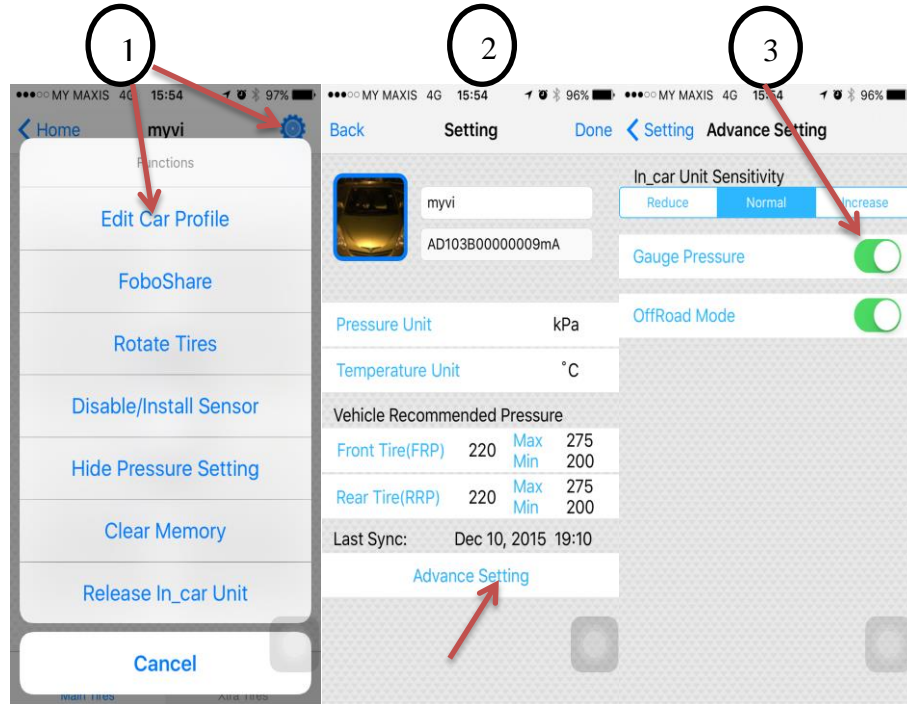

5.11 How to turn on FoboSignal +

To turn on FoboSignal +:

- i. At the Car Status screen, click the settings icon at the top Right corner.
- ii. Select “FoboSignal+ on/off”.
- iii. Follow the instructions on the screen.

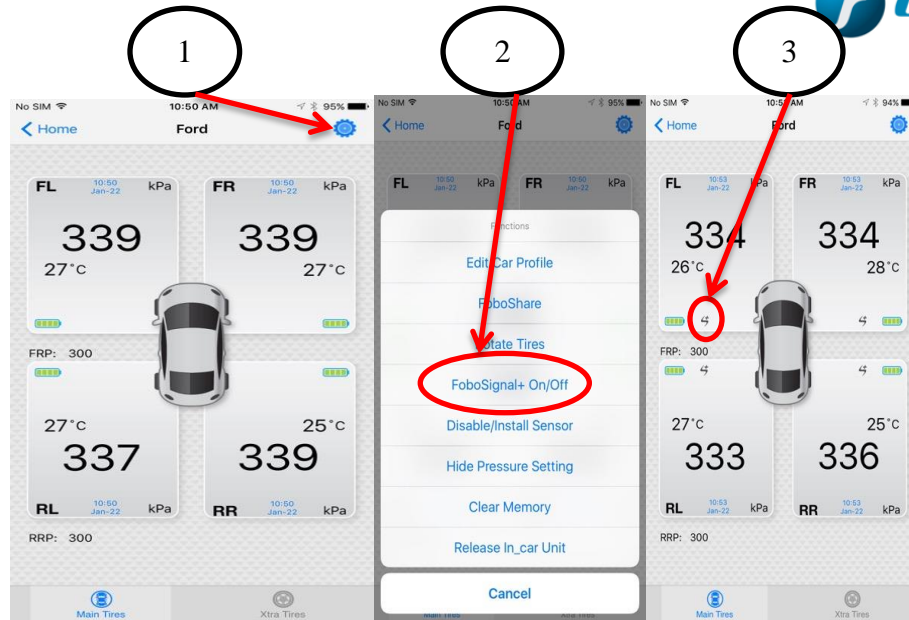

This feature will enhance sensor signal reception. It is useful if the user is facing a problem in receiving signals from the sensors due to interference.

For power consumption, use of FOBO Signal + may reduce the battery life by 25% to 30%. If your sensor range and signal is fine, then you don't need to use this feature.

5.12 How to turn on Off Road Mode

To turn on Off Road Mode:-

- 1) At the Car Status screen, click the gear icon at the top Right and select “Edit car Profile”.
- 2) Click at Advance Setting.
- 3) Turn on the Off Road Mode by swiping the button.

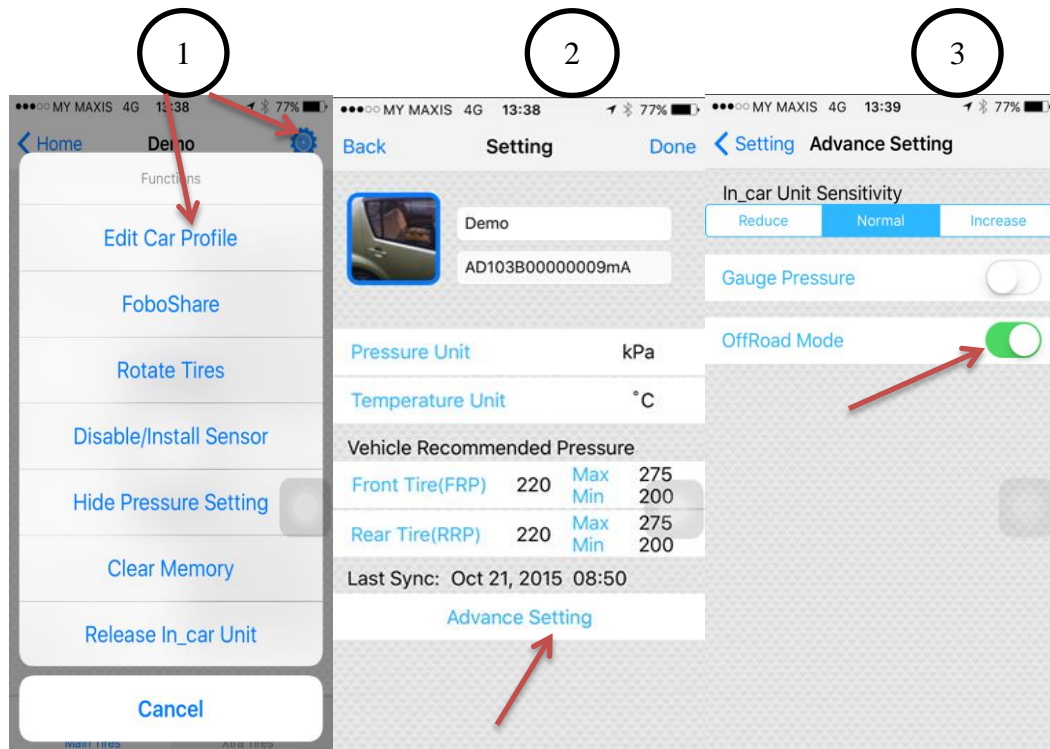

Users can set the Pressure limit below 160Kpa/23Psi if they turn on the Off Road mode.

CAUTION:

Do not use Off Road mode on normal roads, it's only to be used for Off-Road activities where lower tire pressure is required.

5.13 Tire Inflation/Deflation

To Inflate/Deflate the tire user just need to unscrew the sensor, inflate/deflate the tire then screw back the sensor on tire valve. User do not need to release or disable the sensor.

5.14 Reference pressure at 20 deg C:

Reference pressure is a temperature-compensated tire pressure referenced back to a standard temperature of 20 degree Celsius. This is useful and serves as a guide for the user to decide on the approximate amount of air needed to inflate the tire during hot season or immediately after a long drive.

The reference pressure reading is located above/below the actual pressure reading in blue with smaller font size. The user has an option to show / hide the reference

pressure reading for individual profile by going to the “settings” at top right corner on the car status screen.



5.15 Overlay service:

“Overlay service” feature is an effective approach which helps the users to get the latest pressure, temperature and battery readings just by a single click on the FOBO overlay icon which is displayed on the mobile home screen without the need of going into the FOBO Tire App. Through this feature user can use any other App in the foreground with live FOBO readings displayed on the screen.

To turn on the Overlay Service:

1. Open the FOBO Tire App.
2. Click on the General settings (Wheel icon at top right of screen) on the HOME screen of FOBO Tire App.
3. Turn on the Overlay service under UI settings.
4. Upon turning on the Overlay service FOBO overlay icon will appear on the screen.
5. Click on the FOBO overlay icon to get the pressure, temperature and battery readings.

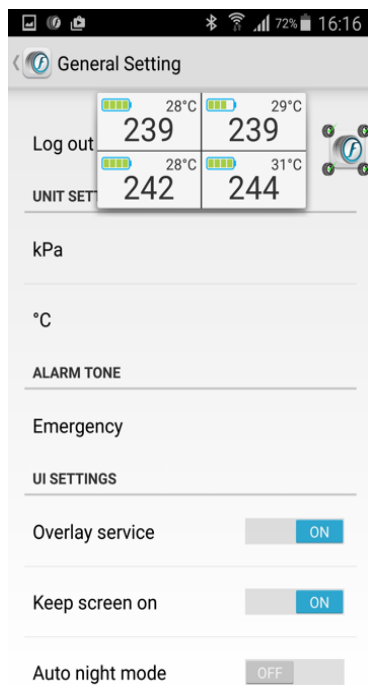
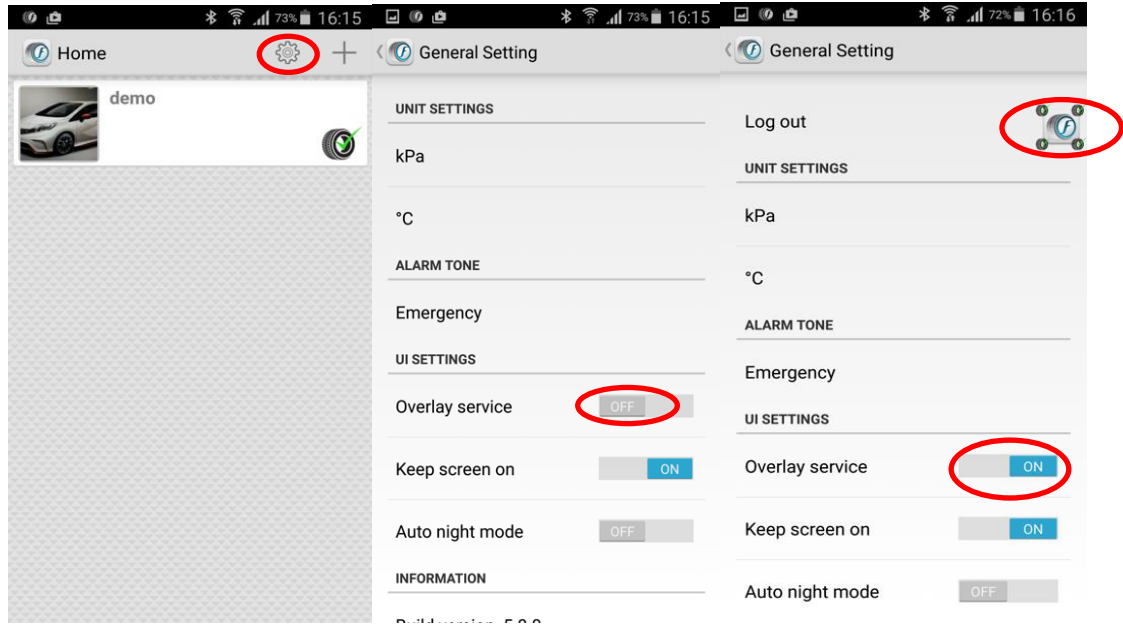

5.16 Sensor status in the App:

It is always recommended to open the App and check all the tire positions status prior to start driving. There could be an event that user in-car unit battery already flat and user left it unattended, subsequently if the sensor battery goes flat then user will not get any alert, as the alerts will only route through the in-car unit.

Each time prior to start driving user need to ensure that the in-car unit gives wake-up sound, it will ensure that the in-car unit is in working condition and the batteries are good. If user did not hear the wake up sound, then press the side button of in-car unit to check the in-car unit is awake and batteries are not flat. Please do not delay in changing the batteries of the in-car unit if it is flat, otherwise system will not work as designed and it will affect the functionality of the whole system.

User can check the sensor status by opening the App in the foreground, if the tire positions box are showing readings in Black color with white color background then the readings are live, if the readings are in grey color with grey color background then the readings are old. User can always check the timestamp which is located on the individual tire position to check when the last time smartphone received readings from the sensor.

User will get “ERR” message in the App if sensor battery is flat; battery level indicator is another great reminder for the user to change the sensor battery. If the

In-car unit is damaged or battery flat and subsequently any of the sensor battery goes flat then the App will grey out the respective tire position rather than showing the “ERR”.

Below are the pictures showing the difference between live and old data:

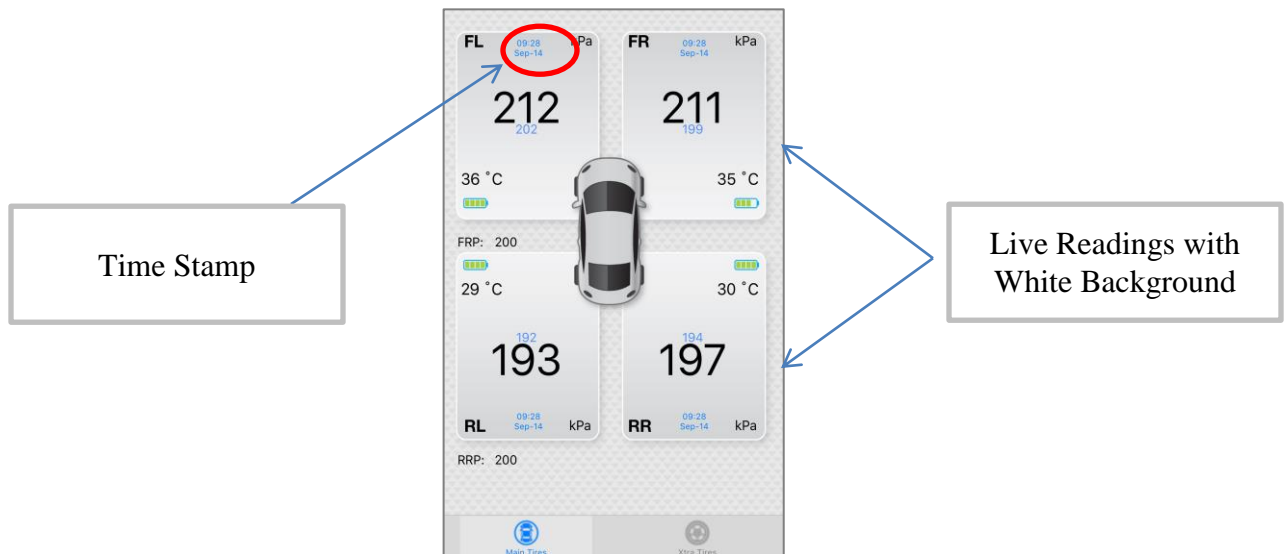

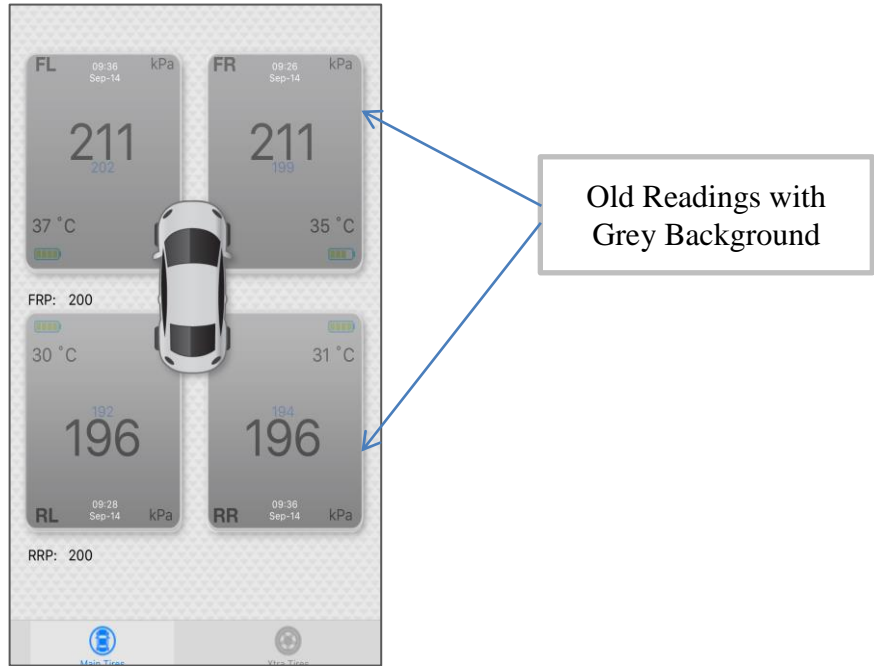

5.17 Auto Night Mode:

When this mode is turned on, the App will automatically display in predefined brightness/color scheme conducive for viewing when the ambient brightness is low. The App uses location service to determine the local time to turn on the night mode. Do ensure the smartphone's location service is enabled for the app so that this feature can work as designed. Users can enable this mode in General setting of the App

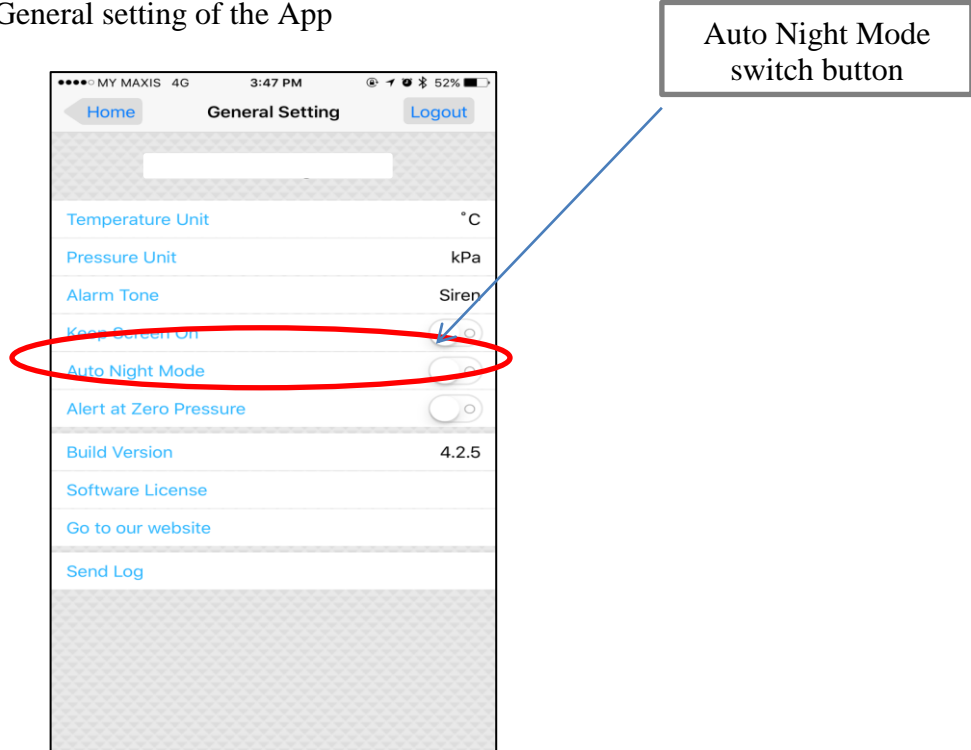

6 FOBO Tire Plus Alert Messages

You will get the following alert messages below on your smartphone during the operation of FOBO Tire Plus under different conditions. The In Car unit will also generate different alert tones to distinguish the severity of the alert. When you get a continuous non-stop two-tone alert, please find a safe location to stop your car and check the alert messages on the smartphone.

A. Soft Alert – In-Car unit will beep 5 tone alert every 5 minutes for 15 minutes –

6.15 Pressure below preset limit

You will receive this soft alert when the tire pressure drops below the pre-set lower limit. The pre-set value for the low limit is 8% below the recommended pressure that you have set or below 160kPa, whichever that is higher. You can change this lower limit in the advance setting down to a minimum of 160kPa (1.6 bar/23 psi). For fuel economy and optimum tire performance, it is recommended to maintain this 8% range so that you can keep your tires inflated optimally. If you find the reminder is too frequent, you may want to check your tire for any leakage. Note that drastic temperature drop may also cause tire pressure drop. Please check your tire pressure and re-inflate during change of seasons.

Note: The hard limit for low pressure is fixed at 160kpa (1.6bar/23psi) and cannot be change by the user.

6.16 Pressure above preset limit

You will receive this soft alert when the tire pressure increases above pre-set upper limit. The pre-set value for upper limit is 25% above recommended pressure or above 595kPa (5.95bar/86psi), whichever that is lower. You can change this upper limit in the advance settings up to a maximum of 595kPa (5.95bar/ 86psi). For optimum tire performance and grip, you should not overinflate your car tires. Note that the tire pressure will naturally increase as

the car tires heat up due to friction while driving. However, you should check your tire in the event of an abnormal rise in the tire pressure.

Note: The hard limit for high pressure is fixed at 595kpa (5.95bar/86psi) and cannot be change by the user.

6.17 Sensor battery level low

You will receive this soft alert when the sensor battery level drops to certain level. Please change the battery immediately after you receive this alert. You will continue to receive this alert every time you start moving your car until the battery is changed.

6.18 In-Car unit battery level low

You will receive this soft alert when the In-Car unit battery reaches a certain low level. Please change the battery immediately after you receive this alert. You will continue to receive this alert every time you start moving your car until the battery is changed.

B. Emergency Alert – In-Car unit will beep continuously non-stop with a two tone alert every 3 seconds for 15 minutes.

6.19 Pressure too low

You will receive this emergency alert when the tire pressure drops 15% below the recommended pressure that you set or when the tire pressure is below 160kPa (1.6 bar/ 23psi), whichever that is higher. **NOTE: IT IS DANGEROUS TO DRIVE WITH LOW TIRE PRESSURE AND IT MAY LEAD TO A BLOW-OUT. PLEASE STOP THE VEHICLE AND HAVE THE TIRE CHECKED WHEN YOU RECEIVE THIS ALERT.**

6.20 Pressure too high

You will receive this emergency alert when the tire pressure is 35% above the car tire recommended pressure that you set or when the tire pressure is above 599kPa(5.99bar/87psi), whichever that is lower. **NOTE: THIS IS AN ABNORMAL RISE IN THE TIRE PRESSURE. PLEASE STOP THE VEHICLE AND HAVE THE TIRE CHECKED WHEN YOU RECEIVE THIS ALERT.**

6.21 Temperature too high

You will receive this emergency alert when the temperature detected exceeds 65°C/149°F. Note that the temperature inside the tire may be higher than the temperature detected by FOBO Tire Plus sensors due to the air cooling effect on the tire valve when the car is moving. It is extremely dangerous to drive when you get this alert message. **WARNING: WHEN YOU RECEIVE THIS ALERT, PLEASE STOP YOUR CAR IMMEDIATELY AND CHECK THE TIRE!**

6.22 Signal low or sensor missing

You will receive this emergency alert when the In-Car unit fails to communicate with the tire sensor. It could be the sensor signal is blocked, sensor unit damaged or missing from the tire. If confirmed the sensor is damaged or missing, you could disable the sensor in order to continue using FOBO Tire Plus with remaining working sensors. Please purchase the sensor replacement immediately. It is not advisable to continue driving without FOBO Tire Plus actively monitoring one or more of your car tires.

6.9 Pressure Drop too fast

For fast air leak, FOBO Tire smartly alerts the user when it matters the most. FOBO sensors sense the pressure every **8 seconds**, if the pressure changes more than **15 Kpa** OVER this time frame, the sensor will immediately send an updated pressure signal to the phone which will trigger an alert on the FOBO Tire App in the event the pressure has breached the upper or lower limit (Applicable to all 3 alert levels).

If there is a sudden drop in pressure (**say from 200 Kpa to 0 Kpa**) in **LESS than 8 seconds**, the App will not alert you because the App will treat this as though you have removed the sensor to inflate your tire. The system is designed this way as we believe that if there is an instant drop to 0 pressure, the user would have already felt it before getting any alert from the TPMS (like getting a burst, or hitting a kerb/drain, etc.)

7 In-Car unit audio & LED alerts

The In-Car unit will produce different tones and LED flashes for different situations. For repetitive alerts, you can stop the alerts by pressing the In-Car unit side button once. In case you have forgotten the location of the problematic tire, you can short press the side button another time to re-produce the alert one time.

Wake up – unit will produce “di da” tone once with LED blinking sequentially for all four tire indicators. This shows that In-Car unit is awake and operational.

Sleep – unit will produce “daaa” tone once. No LED blink. This shows In-Car unit is going to sleep and not operational. In-Car unit goes to sleep to conserve battery when car is not moving for a long time. However the sensors will still be operational 24x7 and continue to monitor and alert to your smartphone in case of flat tire.

Soft alert – unit will produce “di di di di di” tone once and repeat every 3 minutes. LED will blink for 5 seconds on problematic tire. This alert is for non-emergency situation such as:-

- Tire pressure slightly exceed above or below user pre-set limits. It is not dangerous to continue driving.
- Sensor battery low. Once notified on low sensor battery, please remember to change the battery as soon as possible. Do not leave the unit to continue operating under low battery for a long time.
- In-Car unit battery low. LED blink will be on the status LED, not on the tire indicator LED. Once notified on low sensor battery, please remember to change the battery as soon as possible. Do not leave the unit to continue operating under low battery for a long time.
- Signal low or sensor missing. For this situation, the tone will repeat every 5 seconds instead of 3 minutes to inform user of a possible missing sensor.

Emergency alert – unit will produce “di da di da di da” tone once and repeat every 5 seconds. LED will continue to blink on problematic tire. This alert is for emergency situation such as:-

- Tire pressure is too high or too low. It is not recommended to continue driving without checking the condition of the tire. Please stop the car at a safe location to check the condition of the tire.
- Tire temperature is too hot, exceeding 65°C or 149°F. It is not recommended to continue driving without checking the condition of the tire. Please stop the car at a safe location to check the condition of the tire. Note that the measured temperature may be lower by 10°C or 50°F compared to the actual temperature of the air inside the tire when the car is moving, due to the cooling effect on the tire valve.

WARNING: FOBO TIRE PLUS IS A MONITORING DEVICE TO ALERTS THE USER WHEN IT DETECTS SIGNALS THAT IS OUT OF PRE-SET CONDITIONS BASED ON THE SETTING BY THE USER. THE USER OR



**DRIVER IS SOLELY RESPONSIBLE TO FIND OUT THE ACTUAL
CONDITION OF THE TIRE AND TO ENSURE PROPER TIRE
MAINTENANCE. FOBO TIRE PLUS IS NOT RESPONSIBLE FOR
WRONG DIAGNOSTICS OR FALSE ALERTS THAT MAY CAUSE
INCONVENIENCE.**

Summary of Alerts:

Alarm Level	Trigger Point when threshold breached	Remarks	App Alerts
1st Level (L1)	8% below 25% above	Soft alerts	In-Car unit will beep 5 tone alerts “di di di di di” every 5 minutes for 15 minutes. LED will blink on problematic tire position. App will notify the user with notification message showing “ Tire pressure below preset”
2nd Level (L2)	15% below 35% above	Emergency alerts	In-Car unit will beep continuously with two tone alert “di da di da di da” every 3 seconds for 15 minutes. LED will blink on the problematic tire position. App will notify the user with notification message showing “ Tire pressure too low”
3rd Level (L3)	Below 160 Kpa 45% above	Emergency alerts	In-Car unit will beep continuously with a two tone alert “di da di da di da” every 3 seconds for 15 minutes. LED will blink on the problematic tire position. App will notify the user with notification message showing “ Deflated Tire detected”
	Missing Sensor	Emergency alerts	Same as L2, App will show ERR for the problematic tire position and the notification message will display “ Tire Low signal or Sensor Missing”
	High Temperature (above 65 ⁰ C)	Emergency alerts	Same as L2
	Battery Low	Soft alerts	Same as L1
For further details on the Alerts, Kindly refer to Section 6 of this Manual.			

8 Replacing Battery

The coin cell battery (CR2032) used in the FOBO Tire Plus sensors could last up to two years based on normal operating condition. Similarly the AA battery used in FOBO Tire Plus In-Car unit could last up to two years based on normal operating condition. Operating in extreme cold or hot temperatures may reduce battery operating life for both the tire sensors and the In-Car unit.

You will receive an alert on the smartphone and In-Car unit when the sensor or In-Car unit battery levels are low. You will be alerted every time you start to drive your car until the battery is replaced. It is advisable to change the battery once you receive this battery alert to ensure proper performance of FOBO Tire Plus. Do not wait until the battery is fully drained as it will cause FOBO Tire Plus to stop working properly.

To replace the battery of sensor unit, unscrew the top cover. Be careful not to damage the rubber gasket as it may affect water resistance of the sensor unit. Ensure the battery (CR2032) is inserted with the “+” sign facing up, away from the PCB.

To replace battery for the In-Car unit, slide out the battery cover. Ensure the battery (AA) is inserted in the correct orientation. It is advisable to use good quality AA batteries (recommended Lithium or Alkaline) for longer lasting performance of In-Car unit.

WARNING: RE-USING OLD BATTERIES OR MIXING OLD AND NEW BATTERIES IN THE IN-CAR UNIT MAY DAMAGE THE ELECTRONICS.

9 Trouble Shooting Guide

- Could not sign up a new FOBO account (did not receive activation e-mail)
 - Check the e-mail address entry is typed correctly
 - Check the Spam mailbox, in case the e-mail was filtered by the e-mail server
 - Check the smartphone is connected to internet and able to receive e-mail

- Could not sign up a new FOBO account (received activation e-mail)
 - Make sure to click on the “Activation” link of the latest e-mail, in case there are multiple authentication e-mails
 - You should be directed to web page that clearly displayed “FOBO account is activated”.

- Unable to Login after signing up to FOBO App
 - Make sure your e-mail address is typed correctly
 - A verification mail will be sent to your e-mail address
 - Follow the instruction in the mail to activate your account before you can Login
 - Check if internet connection is available on your smartphone

- Unable to pair FOBO Tire Plus In-Car unit
 - Make sure the battery is installed correctly and battery tab is removed.
 - Press the side button on In-Car unit and hold for 2 seconds
 - Make sure your smartphone has Bluetooth 4.0 (Smart Ready) capability. **NOTE: BLUETOOTH 2.0 OR 3.0 WILL NOT WORK WITH THIS DEVICE.**
 - Please check if the FOBO Tire Plus has been paired before to another FOBO account. You'll need to "Release" the FOBO Tire Plus set from the FOBO account that it is paired to, before using on your account. The FOBO Tire Plus is designed to pair with one FOBO account only for theft deterrent feature.
 - Try to reset the Bluetooth manager of your smartphone (for iOS: Settings-> Bluetooth-> OFF->ON). At times the Bluetooth manager may be disrupted which may require manual reset.
 - Try to do a hard reset on the phone.

- Unable to pair FOBO Tire Plus sensors
 - Make sure the sensor is screwed onto a tire valve with pressure above 100kPa
 - Try unscrew the sensor from tire valve, screw it back and try again
 - Make sure the battery is installed correctly with battery "+" on top.
 - Make sure your smartphone has Bluetooth 4.0 (Smart Ready) capability. **NOTE: BLUETOOTH 2.0 OR 3.0 WILL NOT WORK WITH THIS DEVICE.**
 - Try to reset the Bluetooth manager of your smartphone (for iOS: Settings-> Bluetooth-> OFF->ON). At times the Bluetooth manager may be disrupted which may require manual reset.
 - Try to do a hard reset on the phone.

10 FOBO Tire Plus Specifications

- **Bluetooth:** v4.0
- **Supported profiles:** GAP, GATT attributes, Device Information Service, Proximity Reporter, Battery Service
- **Transmit Conducted Power:** +4.0dBm (sensor); -6.0dBm (In-Car)
- **Receiver Sensitivity:** -93dBm@0.1%BER
- **Antenna Return Loss:** -12dB
- **Operating Frequency:** 2.4 GHz
- **Weight:** ~11.5g (sensor – with battery) & ~44.6g (In-Car – without batteries)
- **Sensor Dimension H x D:** 15mm x 26mm
- **In-Car unit Dimension HxWxL:** 25mm x 48mm x 85mm
- **Maximum Pressure:** 600kPa (87psi)
- **Battery Type:** CR2032 (sensor) & AA (In-Car). Operating life up to two years. (NOTE: The battery operating life varies according to usage and climate temperature)
- **Operating Temperature:** -40°C to 85°C(sensor); -20°C to 65°C (In-Car)
- **ESD:** 8kV air, 4kV direct contact
- **Operating Humidity:** up to 90% non condensing at 40°C
- **Dust and Water Proof:** IEC60529 compliant to IP57(sensor)
- **Mechanical & Environmental Reliability Testing Standards:** IEC 60068-2-2, IEC 60068-2-1, ISO 21750, IEC 60068-2-29, IEC 60068-2-5, IEC 60068-2-32, ISO 15184, ISO 2409.

11 Warning

- Take note that FOBO Tire Plus is not meant to function as anti-accident or anti-injury device. FOBO Tire Plus is not a substitute for safe tire maintenance practices. Please take full responsibility of your own safety while driving. And continue to send your car for regular tire check and maintenance.
- Please take extra precaution to acoustics safety when operating the FOBO Tire Plus In-Car unit. Note that placing the FOBO Tire Plus In-Car unit beeper close to your ear may result in injury to the ear or permanent loss of hearing.
- You shall not use the FOBO Tire Plus in any unlawful way that violates any laws.
- Avoid exposing the FOBO Tire Plus In-Car unit and sensors to solvent, fire or extreme temperatures.
- FOBO Tire Plus may fail to function properly if the battery is below optimum level. Replace the battery immediately to continue enjoying full features of FOBO Tire Plus.

CAUTION

THERE MAY BE A RISK OF EXPLOSION IF BATTERY IS REPLACED BY AN INCORRECT TYPE. DISPOSE ALL USED BATTERIES PROPERLY.

12 Regulatory Information

Federal Communication Commission Interference Statement

This device complies with Part 15 of the FCC Rules. Operation is subject to the following two conditions: (1) This device may not cause harmful interference, and (2) this device must accept any interference received, including interference that may cause undesired operation.

This equipment has been tested and found to comply with the limits for a Class B digital device, pursuant to Part 15 of the FCC Rules. These limits are designed to provide reasonable protection against harmful interference in a residential installation. This equipment generates, uses and can radiate radio frequency energy and, if not installed and used in accordance with the instructions, may cause harmful interference to radio communications. However, there is no guarantee that interference will not occur in a particular installation. If this equipment does cause harmful interference to radio or television reception, which can be determined by turning the equipment off and on, the user is encouraged to try to correct the interference by one of the following measures:

- Reorient or relocate the receiving antenna.
- Increase the separation between the equipment and receiver.
- Connect the equipment into an outlet on a circuit different from that to which the receiver is connected.
- Consult the dealer or an experienced radio/TV technician for help.

FCC Caution: Any changes or modifications not expressly Approved by the party responsible for compliance could void the user's authority to operate this equipment.

This transmitter must not be co-located or operating in conjunction with any other antenna or transmitter.

Radiation Exposure Statement:



This equipment complies with FCC radiation exposure limits set forth for an uncontrolled environment. This equipment should be installed and operated with minimum distance 20cm between the radiator & your body.

Industry Canada statement:

This device complies with RSS-210 of the Industry Canada Rules. Operation is subject to the following two conditions: (1) This device may not cause harmful interference, and (2) this device must accept any interference received, including interference that may cause undesired operation.

Ce dispositif est conforme à la norme CNR-210 d'Industrie Canada Applicable aux Appareils radio exempts de licence. Son fonctionnement est sujet aux deux conditions suivantes: (1) le dispositif ne doit pas produire de brouillage préjudiciable, et (2) ce dispositif doit accepter tout brouillage reçu, y compris un brouillage susceptible de provoquer un fonctionnement indésirable.

Radiation Exposure Statement:

This equipment complies with IC radiation exposure limits set forth for an uncontrolled environment. This equipment should be installed and operated with minimum distance 20cm between the radiator & your body.

Déclaration d'exposition aux radiations:

Cet équipement est conforme aux limites d'exposition aux rayonnements IC établies pour un environnement non contrôlé. Cet équipement doit être installé et utilisé avec un minimum de 20 cm de distance entre la source de rayonnement et votre corps.

European Union Regulatory Conformance

This equipment is CE marked according to the provisions of the R&TTE Directive (99/5/EC) and is in compliance with the essential requirements and other relevant provisions of the Directive 1999/5/EC. This equipment meets the following conformance standards:

EN 300 328, EN62479, EN 301 489-1&17, EN 60950-1

EU Declaration of Conformity

Hereby, Salutica Allied Solutions Sdn. Bhd. declares that this Bluetooth device is in compliance with the essential requirements and other relevant provision of Directive 1999/5/EC.

Caution: Changes or modifications to this **FOBO** device not expressly Approved by the party responsible for compliance could void the user's authority to operate it.

Bluetooth Wireless Compatibility:

This **FOBO** device supports the following Bluetooth wireless protocols and profiles:

- Bluetooth core technology v4.0
- Battery Profile (BAS)
- Proximity (PXP)
- Device Information Service (DIS)

Bluetooth Wireless Interoperability:

This **FOBO** device is designed to be interoperating with all Bluetooth wireless products that support compatible profiles and roles including:

- Bluetooth core technology v4.0
- Bluetooth master and slave roles

NCC Statement 低功率電波輻射性電機管理辦法

第十二條 經型式認證合格之低功率射頻電機，非經許可，公司、商號或使用者均不得擅自變更頻率、加大功率或變更原設計之特性及功能。

第十四條 低功率射頻電機之使用不得影響飛航安全及干擾合法通信；經發現有干擾現象時，應立即停用，並改善至無干擾時方得繼續使用。前項合法通信，指依電信法規定作業之無線電通信。低功率射頻電機須忍受合法通信或工業、科學及醫療用電波輻射性電機設備之干擾。

13 Intellectual Properties

- FOBO™ is a trademark of Salutica Allied Solutions Sdn Bhd. All rights reserved.
- FOBO™ Tire incorporates a few patent pending technologies solely owned by Salutica Allied Solutions Sdn Bhd.
- Bluetooth® is a registered trademark owned by Bluetooth SIG Inc.
- iPhone® is a registered trademark of Apple Inc.

14 Limited Warranty & Disclaimer

14.15 Warranty

FOBO Tire Plus comes with a 12 months limited warranty. This Limited Warranty does not cover: 1) products purchased from an unauthorized reseller; 2) products purchased through online auctions; 3) products that are operated in combination with software, peripheral or ancillary equipment such as but not limited to batteries, chargers, adapters, headsets, connector cables, and power supplies ("Ancillary Equipment") not furnished or otherwise certified by Salutica for use with the FOBO products or any damage to the FOBO products or ancillary equipment as a result of such use; 4) damage caused by (a) accident, fire, misuse, neglect, unusual physical or electrical stress, or modification; (b) improper or unauthorized installation, wiring, repair, testing or (c) use of the product outside Salutica's published guidelines; 5) instances in which someone other than Salutica (or its authorized service centers) tests, alters, modifies or services the products in any way; 6) products that have (a) serial numbers or date tags that have been removed or altered, or (b) nonconforming or non-FOBO housings or parts; and 7) consumable spare parts and accessories (unless they are found to be non-functional or broken upon purchase of product).

In order to obtain any warranty service, you agree to bear all shipping charges of the FOBO Tire Plus device to Salutica's address.

14.16 Disclaimer

SALUTICA MAKES NO OTHER EXPRESS WARRANTY WHETHER WRITTEN OR ORAL AND SALUTICA EXPRESSLY DISCLAIMS ALL WARRANTIES AND CONDITIONS NOT STATED IN THIS LIMITED WARRANTY. TO THE EXTENT ALLOWED BY THE LOCAL LAW OF JURISDICTIONS OUTSIDE MALAYSIA, SALUTICA DISCLAIMS ALL IMPLIED WARRANTIES OR CONDITIONS, INCLUDING ANY

IMPLIED WARRANTIES OF MERCHANTABILITY AND FITNESS FOR A PARTICULAR PURPOSE. FOR ALL TRANSACTIONS OCCURRING IN MALAYSIA, ANY IMPLIED WARRANTY OR CONDITION OF MERCHANTABILITY, SATISFACTORY QUALITY, OR FITNESS FOR A PARTICULAR PURPOSE IS LIMITED TO THE WARRANTY PERIOD AS PROVIDED BY SALUTICA IN THE MATERIALS RECEIVED AT THE TIME OF PURCHASE.

No warranty is made that the software provided by Salutica will meet your requirements or will work in combination with any hardware or Applications software products provided by third parties, that the operation of the software products will be uninterrupted or error free, or that all defects in the software products will be corrected.

14.17 Limitation of Liability

THE MAXIMUM LIABILITY OF SALUTICA UNDER THIS LIMITED WARRANTY IS EXPRESSLY LIMITED TO THE LESSER OF THE PRICE YOU HAVE PAID FOR THE PRODUCT OR THE COST OF REPAIR OR REPLACEMENT OF THAT PRODUCT OR ANY COMPONENT OR PART THAT MALFUNCTION IN CONDITIONS OF NORMAL USE. EXCEPT AS INDICATED ABOVE, IN NO EVENT WILL SALUTICA BE LIABLE FOR ANY DAMAGES CAUSED BY THE FOBO TIRE PLUS PRODUCT OR THE FAILURE OF THE PRODUCT TO PERFORM, INCLUDING ANY LOST PROFITS OR SAVINGS OR SPECIAL, INCIDENTAL, OR CONSEQUENTIAL DAMAGES. SALUTICA IS NOT LIABLE FOR ANY CLAIM MADE BY A THIRD PARTY OR MADE BY YOU FOR A THIRD PARTY. THIS LIMITATION OF LIABILITY APPLIES WHETHER DAMAGES ARE SOUGHT, OR A CLAIM MADE, UNDER THIS LIMITED WARRANTY OR AS A TORT CLAIM (INCLUDING NEGLIGENCE AND STRICT PRODUCT LIABILITY), A CONTRACT CLAIM, OR ANY OTHER CLAIM. THIS LIMITATION OF LIABILITY CANNOT BE WAIVED OR AMENDED BY ANY PERSON. THIS LIMITATION OF LIABILITY WILL BE EFFECTIVE EVEN IF YOU HAVE ADVISED SALUTICA OR AN AUTHORIZED REPRESENTATIVE OF SALUTICA OF THE POSSIBILITY OF ANY SUCH DAMAGES. THIS LIMITATION OF LIABILITY, HOWEVER, WILL NOT APPLY TO CLAIMS FOR PERSONAL INJURY.

14.18 What Law Governs This Warranty

THIS LIMITED WARRANTY IS GOVERNED BY AND CONSTRUED UNDER THE LAWS OF MALAYSIA.