

# **FOBO TIRE LITE**

## **User Manual**

v.1.1.0

(For iOS 13 and Android 8.0 or later)

# Contents

- 1 Introduction
- 2 About FOBO TIRE LITE
- 3 Importance of Tire Care
- 4 Product Description of FOBO TIRE LITE
  - 4.1 TIRE LITE Sensor Unit (TM1802)
  - 4.2 Sensor Lock Nuts & Wrench
- 5 Using FOBO TIRE LITE
  - 5.1 Installing FOBO TPMS App
  - 5.2 Installing FOBO TIRE LITE Sensors
  - 5.3 Setting Up Multiple Users (FOBO Share)
  - 5.4 Disable and Enable Sensor
  - 5.5 Release and Install Sensor
  - 5.6 Swap and Rotate Sensor
  - 5.7 Transfer FOBO TIRE LITE to Another User
  - 5.8 Gauge Pressure
  - 5.9 Off-Road Mode
  - 5.10 Tire Inflation / Deflation
  - 5.11 Reference Pressure
  - 5.12 Overlay Services (Android Only)
  - 5.13 Dark Mode
  - 5.14 Spare Tire Sensor Installation
  - 5.15 General Settings Page
  - 5.16 Theme Colour
  - 5.17 Vehicle Settings Page
  - 5.18 Vehicle Details Page
  - 5.19 Sensor Graph
  - 5.20 Sensor Firmware Upgrade
  - 5.21 Support Page
- 6 FOBO TPMS Alert Messages
  - 6.1 Pressure Below Pre-set Limit
  - 6.2 Pressure Above Pre-set Limit
  - 6.3 Sensor Battery Level Low

- 6.4 Pressure Too Low
- 6.5 Pressure Too High
- 6.6 Temperature Too High
- 6.7 Signal Low or Sensor Missing
- 6.8 Pressure Drop Too Fast
- 7 Replacing Battery
- 8 Trouble-shooting Guide
- 9 FOBO TIRE LITE Specifications
- 10 Warning
- 11 Regulatory Information
- 12 Intellectual Properties
- 13 Limited Warranty and Disclaimer
  - 13.1 Warranty
  - 13.2 Disclaimer
  - 13.3 Limitation of Liability
  - 13.4 What Law Governs This Warranty.

# 1 Introduction

FOBO TIRE LITE is a SMART Tire Pressure Monitoring System (TPMS) for 4 wheelers. FOBO TIRE LITE can monitor up to 800kPa (116psi). With its patented technologies, it provides the following features/functions:

- View on demand tire pressure & temperature,
- Monitors tire pressure in real time while driving or when in Bluetooth range,
- Detects slow or fast leak and alerts users to anomalies,
- Sends instant alerts on a smartphone / smart watch,
- Easy to install without running wires, drilling holes, and tedious programming.

FOBO TIRE LITE uses Bluetooth 5.0 (sensors) technology for connectivity to monitor your car tire pressure and temperature. Bluetooth Smart is a very low power wireless technology that could operate on a single coin cell battery for up to 1 year.

**(NOTE: Battery life may vary according to usage and climatic temperature. Operating under extreme cold may drastically reduce battery life.)**

Please ensure that your smartphone has Bluetooth Smart Ready (Bluetooth 4.0 or above) capability to use FOBO TIRE LITE. Currently the FOBO TIRE LITE's companion app, FOBO TPMS, works best with iOS 13 and Android 8.0 or later.

Before starting to use FOBO TIRE LITE, please download FOBO TPMS app onto your smartphone from Google Play Store or Apple App Store.

FOBO TIRE LITE is a product designed and produced by Salutica Allied Solutions Sdn. Bhd. ("Salutica"), a Malaysian company with its address at No. 3, Jalan Zarib 6, Kawasan Perindustrian Zarib, 31500 Lahat, Ipoh, Perak, Malaysia.

## 2 About FOBO TIRE LITE

FOBO TIRE LITE monitors your car tires non-stop around the clock. Most drivers have encountered situations where they need to rush for an urgent appointment only to be stranded by a flat tire. Conventional Tire Pressure Monitoring Systems (TPMS) could not alert you in advance because it stops operating as soon as the car ignition is switched-off. With FOBO TIRE LITE, you will get an alert as soon as the tire pressure drops below a certain pre-set level, even when the car ignition is switched off as long as you are within Bluetooth range (~30m). This alert gives you time to get the flat tire fixed before you need to use it.

The FOBO TPMS app can monitor up to 19 vehicles concurrent monitoring in background and unlimited in foreground on each smartphone. You can receive data from the tire pressure sensors from all your cars without switching on the ignition. The FOBO TPMS app allows you to monitor your car tires conveniently any time you want.

**NOTE: Under certain conditions the signals from FOBO TIRE LITE sensors may be blocked by surrounding objects or structures. If this occurs, please move around the vehicle to capture signals from all the sensors.**

If you are sharing your car with family members or friends, you can allow others to use access your FOBO TIRE LITE sensors through the FOBO Share function. After adding them through FOBO Share, family members or friends using your car will receive alerts and data from your FOBO TIRE LITE on their own smart phone immediately.

FOBO TIRE LITE consists of 4 tire sensors. Replace your tire valve caps with the sensors. The sensors will measure tire pressure of each tire and transmit via Bluetooth to your smartphone. In case of any problem, alerts will pop up on your smartphone through the app.

FOBO TIRE LITE system requires a smartphone and app for installation. In addition to being able to view information regarding your car tire pressure and temperature, the FOBO TIRE LITE smartphone app will also produce an alert when your tire has a problem.

**DISCLAIMER: FOBO TIRE LITE IS NOT A DEVICE THAT PREVENTS ACCIDENTS. IT IS ALSO NOT A DEVICE THAT PREVENTS TIRES FROM BECOMING DEFLATED OR OVERINFLATED. FOBO TIRE LITE IS NOT A SUBSTITUTE FOR SAFE TIRE MAINTENANCE PRACTICES. PLEASE CONTINUE TO TAKE PRECAUTIONARY MEASURES WHILE DRIVING AND TAKE FULL RESPONSIBILITY OF YOUR VEHICLE'S TIRE CONDITION TO ENSURE SAFETY WHILE DRIVING. YOU SHOULD CONTINUE TO PRACTICE PROPER TIRE CARE AND SCHEDULED TIRE MAINTENANCE.**

### **3 Importance of Tire Care**

It is extremely important to ensure car tires are properly inflated for safety while driving. However, many drivers tend to neglect proper tire care and maintenance. The car tires are the only contact points between the car and the road. The weight of the car and passengers are supported by the air pressure inside the tires. Improperly inflated car tires may cause serious accidents on the road.

When tires are underinflated, the additional rolling resistance may cause build-up of heat which may lead to the de-lamination of the tire materials as well as damage to the tire's sidewall thus increasing the chances of a tire blow-out. Underinflated tires will also cause accelerated wear on the tire shoulders thereby causing uneven tire

wear. Gas mileage will also be affected due to additional rolling resistance when driving with underinflated tires. You would also experience a significant loss of steering precision and cornering stability. Significantly under-inflated tires will also be less effective in resisting hydroplaning.

On the other hand, an overinflated tire will cause accelerated wear on the centre portion of the tire resulting in uneven tire wear. It would also result in a harsher ride and makes the tire more susceptible to damage when going over potholes or debris on the road.

What is the optimum tire pressure? There are a lot of information about this subject in Internet forums and web articles. A quick guide for better understanding of tire pressure below: -

- 1) Car manufacturers recommend the optimum tire pressure for their car models. The information is usually available on a sticker at the door (side of the driver's door) or in the owner's manual. For some car models, the information sticker may be on the trunk lid or on the fuel door. Car manufacturers usually recommend different tire pressure for front and rear tires. This pressure is usually recommended for comfort driving and optimum performance of the car. It is not advisable to go below this recommended pressure level.
- 2) The car manufacturer recommended tire pressure is "cold pressure". When you drive your car to the gas station, the friction on the road will heat up your car tires within a few minutes. Typically, there will 1 psi (~7kPa) increase in air pressure for every 10-degree F (5.6-degree C) rise in temperature. It is advisable to inflate the tire pressure with this compensated pressure above the recommended pressure.
- 3) Air pressure in tires is affected by changes in temperature. Check and adjust your tire pressure whenever there is a drastic change in environment temperature, e.g. Change of season.
- 4) A tire will normally lose its pressure through natural causes unless accelerated by a puncture, faulty valve or damaged wheels. It is advisable to change the tire valves or at least check the valves condition every time you change a new set of tires. Under normal condition, a set of tires could deflate at a rate of up to 2psi per month. It is good practice to check your tire pressure regularly and top up to the optimum pressure.
- 5) Every car tire has a maximum inflation pressure. It is not advisable to inflate to the maximum inflation pressure of the tire. Follow the car manufacturer's recommended tire pressure instead.

## 4 Product Description of FOBO TIRE LITE

### 4.1 Tire Sensor Unit (TM1802)

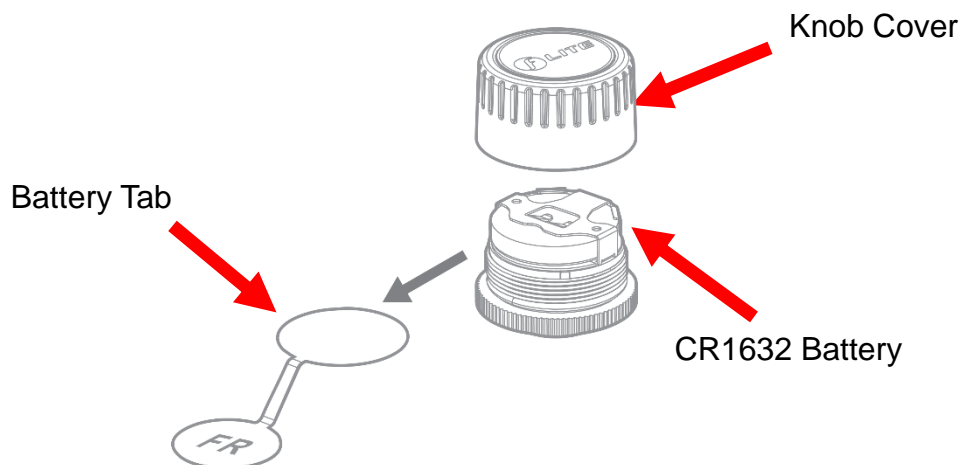

#### Knob Cover

Waterproof cover. Please ensure the red silicon ring is intact to prevent water from getting into electronics compartment.

#### Single Internal Battery

CR1632 coin cell battery. When replacing battery, please ensure the “+” sign of the battery is facing up, away from PCB.

#### Internal PCB

Internal electronics circuit (The pressure sensor chip is mounted within this PCBA, and it senses the tire pressure against a built-in vacuum, resulting in an Absolute Pressure reading. The internal firmware will then subtract the sea-level pressure of 101.3 kPa (14.7 psi) from this reading. This final reading which will be shown in the app can be termed as:

- i) Tire Absolute Pressure minus sea level pressure, or
- ii) Gage Pressure reference to sea-level altitude.

With this formulation, FOBO Tire LITE sensor will read the same pressure value for any given time, irrespective of altitude (assuming a constant temperature). This will ensure the correct tire footprint per vehicle manufacturer’s pressure recommendation, for all altitude above sea-level, given a constant temperature.

As a corollary, a tire with a FOBO reading of, say 40 psi at an altitude of 5000ft, will read the same 40 psi when driven to sea-level, given a constant temperature. However, it will read higher due to the warmer temperature at

sea-level and may need some air release if the temperature difference is great. Tire pressure generally will increase 1 psi (~7kPa) for every 10-degree F (5.6-degree C) rise in temperature.

FOBO wishes to highlight the above formulation is for usage at sea-level and above and will not be accurate for use otherwise. In practice, this should not be an issue as the lowest area on earth will result in an insignificant error of 0.3 psi (~2 kPa).

For users who wish to retain 'Gauge Pressure Reading', the FOBO TPMS app has a Gauge Pressure, adjusted to local altitude using cell towers or individual phone barometer if available.

### **Battery Tab**

Prior to installing a sensor, user need to remove the battery tab from a sensor. Tire position is indicated on the battery tab.

FOBO TIRE LITE sensor units are designed to be robust and operate reliably 24x7 to provide tire information around the clock. It is designed to be water proof (IP57) and by our special use of custom engineering plastics, it will be able to withstand road salts or other common automotive chemicals (petrol, engine oil, car wash shampoo, etc.).

Our designers have designed the sensors to ensure that there is no air leakage as it replaces the tire's original valve cap. There is no need to screw on the sensor extremely tight. Apply a reasonable hand twist force to ensure the sensor is securely installed and should be able to be removed by hand with ease.

A missing or damaged sensor can be replaced easily, through the FOBO TPMS app. You will need to purchase a replacement sensor which you can do so online at: [www.my-fobo.com](http://www.my-fobo.com).

**NOTE:** Battery life span up to one year (for sensor) is an estimate based on normal use at 23 °C. Battery life may vary according to usage and climatic temperature.

### **Battery life span will change due to the following reasons:**

- 1) Frequent change of pressure threshold setting in the app.
- 2) Disabling & enabling of sensors.
- 3) Release & pairing.
- 4) Removal & screw-on of sensors.
- 5) Operating under extreme cold/hot temperature.
- 6) Testing of product.
- 7) Rotation.
- 8) Trigger alert or let activated alerts unattended.
- 9) Multiple removal and screw-on of sensors for equalizing all tire pressures.

All these activities will drain a battery very fast and affect the battery life span.



## 4.2 Sensor Lock Nuts and Wrench



FOBO TIRE LITE sensors are tied to a FOBO account; sensors are pre-installed from the factory. They are not re-usable or transferable without the owner releasing them from his / her FOBO account. This is a theft deterrent feature to discourage theft.

As an additional anti-theft feature, all FOBO TIRE LITE package comes with lock-nuts and special wrench. FOBO TIRE LITE system functionality is not affected if you do not use the lock-nuts.

The lock nuts and wrench are made of custom engineering plastics that can withstand road salts and common automotive chemicals (gasoline, engine oil, car wash shampoo, etc.).

In order to use the lock nuts, you must first install the lock nut to the tire valve (with the bump facing tire rim). Screw in the lock nut all the way down and ensure that there is still a **minimum of 5 thread count** on the tire valve for the sensor unit to be screwed on. If there is insufficient thread for the tire sensor, it may lead to air leakage. A solution for this would be to change the tire valve to one with a longer thread. Next, screw in the tire sensor unit until it is reasonably tight. Then use your finger to unscrew the lock nut outwards (i.e. anti-clockwise) until it pushes against the bottom of the sensor unit. Use the wrench to tighten the lock nut. The resultant friction force will make it difficult to remove the sensor unit without loosening the lock nut. For rubber valves, hold the valve stem with one hand and tighten the lock nut with the wrench on another hand. This is to avoid the rubber valve from twisting making it unable to tighten the lock nut.

**WARNING:** Do not apply too much force to tighten the lock-nut. You may face difficulty to loosen the lock nut later on especially for rubber valves that typically doesn't stay firm on the tire rims.

**NOTE:** If your tire valve is too short, you shouldn't use the lock nut as this will block the sensors from being completely screwed on the tire valve and causes air leak. Our sensors are designed to work on a tire valve with a minimum of 5 thread counts.

It is recommended to apply some soap water (on the tire valve installed with FOBO TIRE LITE sensor) after installing a sensor to check for any leakage.

## Step by Step Diagram How to Use FOBO TIRE LITE Lock-Nut and Wrench

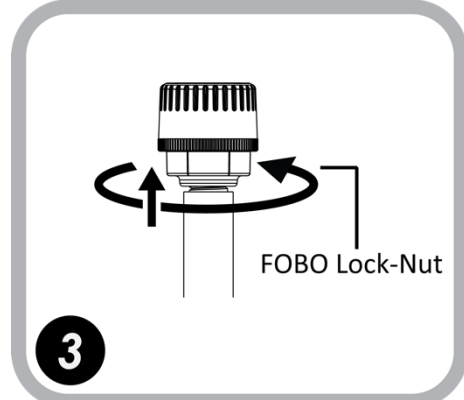
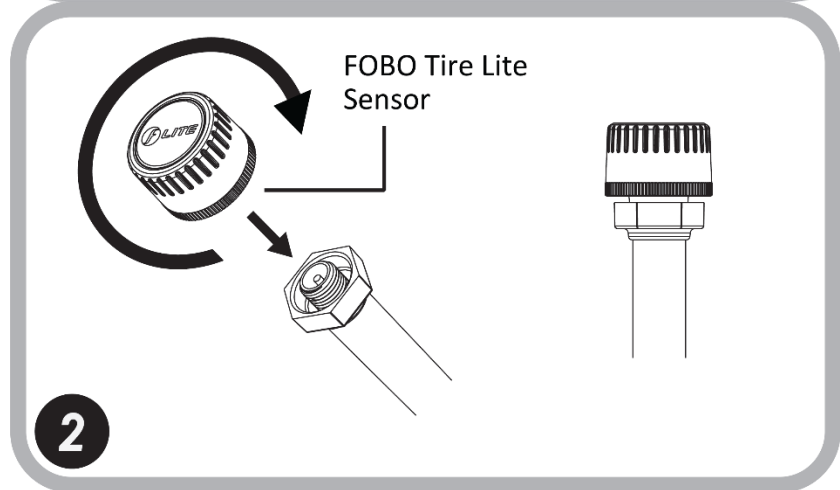
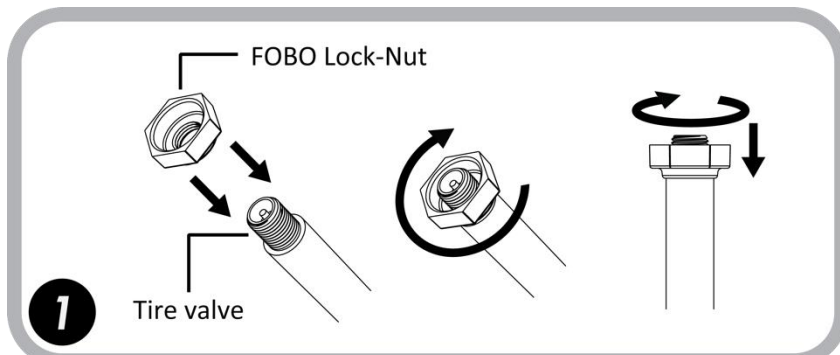

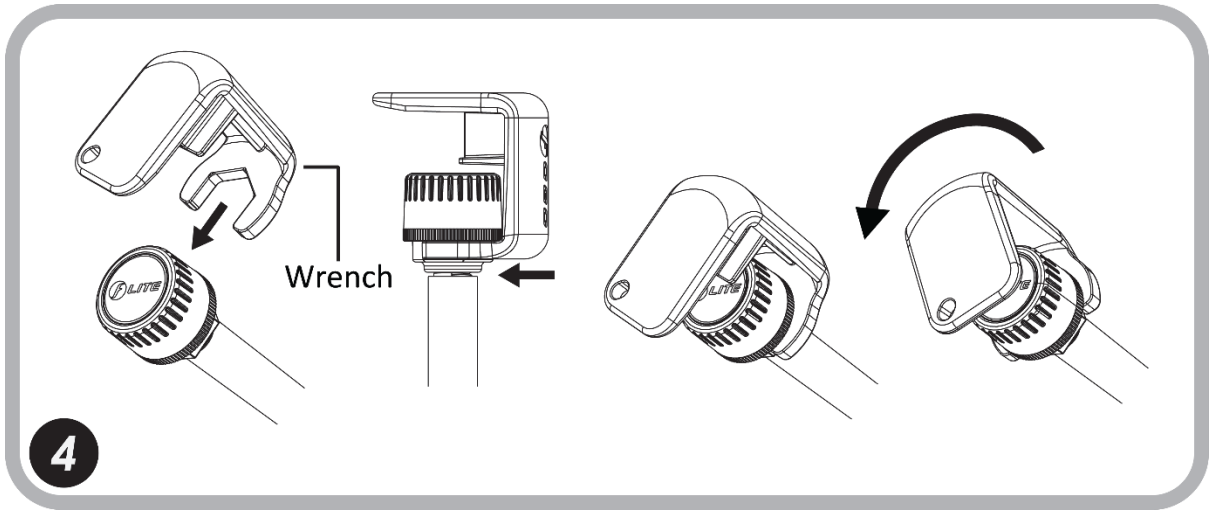

## 5 Using FOBO TIRE LITE

### 5.1 Installing FOBO TPMS App

You are required to have a smartphone with **Bluetooth 4.0** (Bluetooth Smart) capability to use FOBO TPMS app. The smartphone also must be running on iOS 13 and Android 8.0 or later. Follow the steps below to install FOBO TPMS app: -

**Step 1:** Download FOBO TPMS app onto your smartphone.

- For iPhone users, download from Apple's App Store.
- For Android users, download from Google Play store.
- Search for "FOBO TPMS".

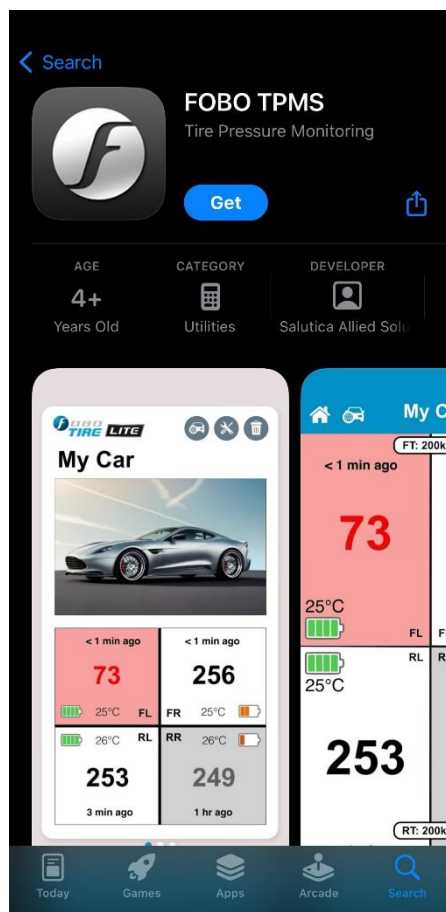

**Step 2:** Launch FOBO TPMS app and sign in using Google or your personal email address.

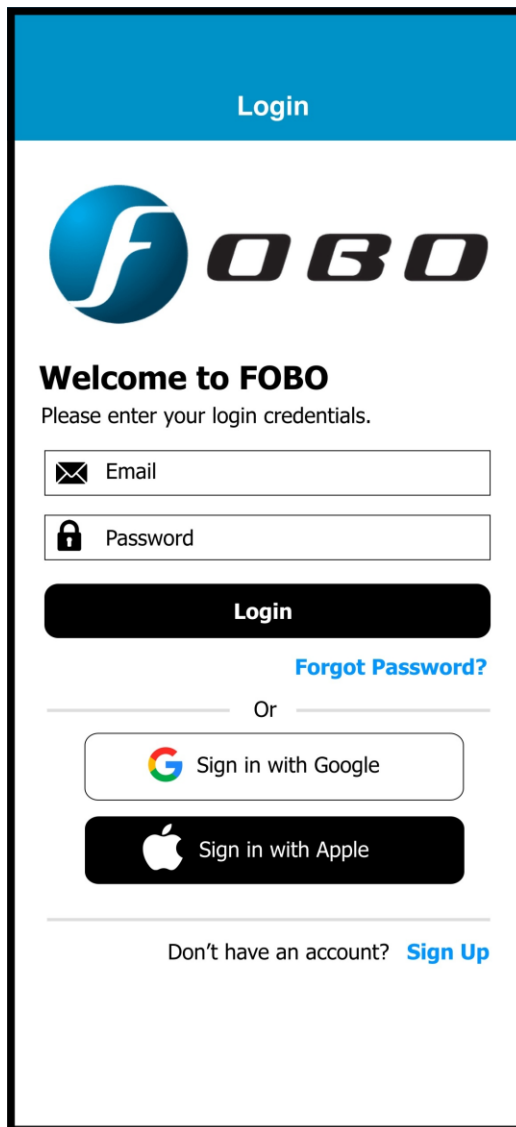

Follow the below steps if you choose to login using your personal email address:

- Key in your Email and Password and the press “Login” button.
- You will be brought to the FOBO TPMS app’s “Home” screen.

**Note:**

- Please remember the password you entered while creating an account. You can click on “Forgot Password” option on the “Login” page to get instructions on how to reset password.
- If you do not receive any email (to reset password) from FOBO Admin after 15 minutes (with a good Internet connection), please write in to [fobo@salutica.com.my](mailto:fobo@salutica.com.my). FOBO representative will be in touch with you to solve the issue.

## **IMPORTANT:**

FOBO TIRE LITE sensors are locked to your FOBO account as an anti-theft deterrent. Stolen sensors cannot be used by anyone else other than the FOBO account owner.

Location service is required to be enabled for the FOBO TPMS app (FOBO TPMS app does not use the GPS function to track your location). The location service on the iOS / Android system has other functionality that the FOBO TPMS app uses to operate properly. It will ensure FOBO TPMS app functions as designed, mainly for alert functions and the gauge pressure feature as required by users living at high altitudes. FOBO TPMS is designed to be a low energy system and does not drain your smartphone battery excessively.

By submitting your information to sign up as a new user account, you acknowledge your acceptance to the terms and conditions of our Software Licensing Agreement and Privacy Policy.

## **5.2 Installing FOBO TIRE LITE**

**NOTE: Please ensure you have good Internet connection otherwise you won't be able to perform the installation.**

TO REDUCE THE RISK OF AN ELECTROSTATIC DISCHARGE (ESD) PLEASE TOUCH THE WHEEL WHEN SCREWING ON THE TIRE SENSOR ON TO THE TIRE VALVE. THIS IS TO MINIMIZE POTENTIAL ESD ATTACK WHICH MAY CAUSE DAMAGE TO THE TIRE SENSOR AND ITS FUNCTION.

INSTALLING FOBO TIRE LITE SETS ON MORE THAN ONE CAR WHICH ARE PARKED CLOSELY TOGETHER MAY CAUSE CROSS INTERFERENCE TO THE BLUETOOTH SIGNALS. PLEASE INSTALL FOBO TIRE LITE ON ONE CAR AT A TIME.

To begin using FOBO TIRE LITE sensor, firstly ensure that the FOBO TPMS app is downloaded, and you have already login to the app (see section 5.1 above for installation and login).

Follow the steps below to pair FOBO TIRE LITE sensor to your smartphone:

- 1) Turn on your smartphone's Bluetooth and Internet connection.
- 2) Open the FOBO TPMS app.
- 3) Allow all the permissions when prompted by the app.
- 4) Press on the plus "+" button on the FOBO TPMS app "Home" page.
- 5) Select "FOBO TIRE LITE" product and press "Next".



- 6) Select the type of FOBO TIRE product. The product comes with a QR Code, select "FOBO TIRE LITE". Once you select the product, press "Next".

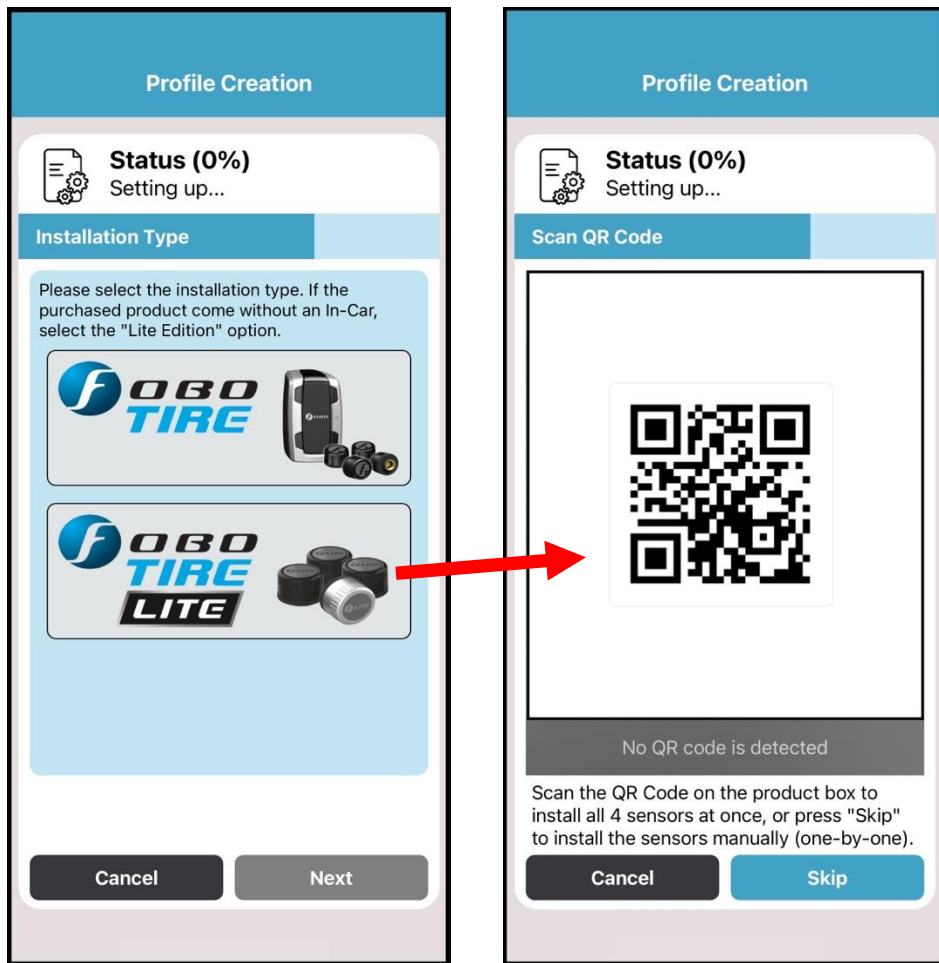

## 7) Product installations:

### a. QR Code Installation (FOBO TIRE LITE)

Select the "FOBO TIRE LITE" product and it will lead you to a page that will open your device's Camera. You will be asked to scan a QR Code image located on the product box to install all 4 sensors.





- 8) After installation is successful, the app will show this page as shown below.

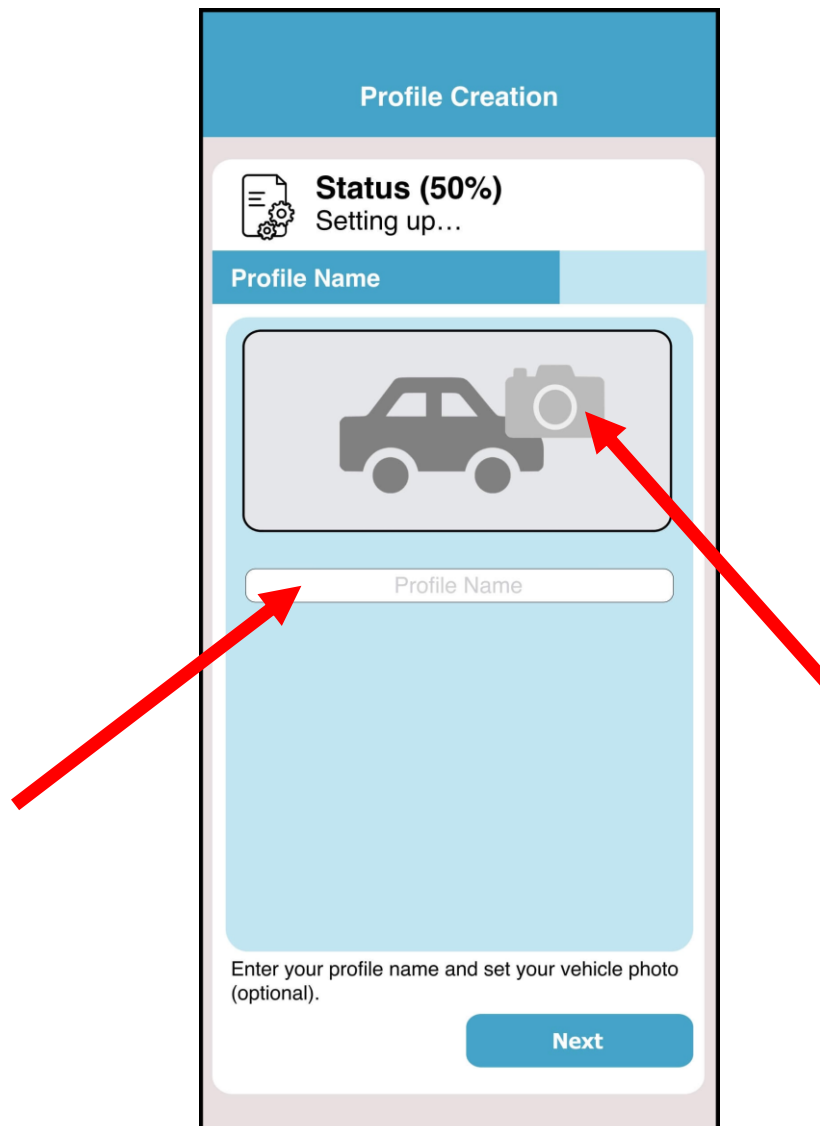

- 9) Under the **Profile Name** section - Tap on the camera icon and choose from the provided options to set up an image for your car profile (optional). Key in a profile name (mandatory) and press on the “Next” button.
- 10) Under **Pressure Settings** section – Set your vehicle recommended tire pressure (“Rec” in the centre) for front and rear axle. Press on the “Next” button.

The recommended tire pressure information for your car is usually available on a sticker at the door (side of the driver’s door) or in the owner’s manual. For certain car models, the information sticker may be on the trunk lid or on the fuel door.

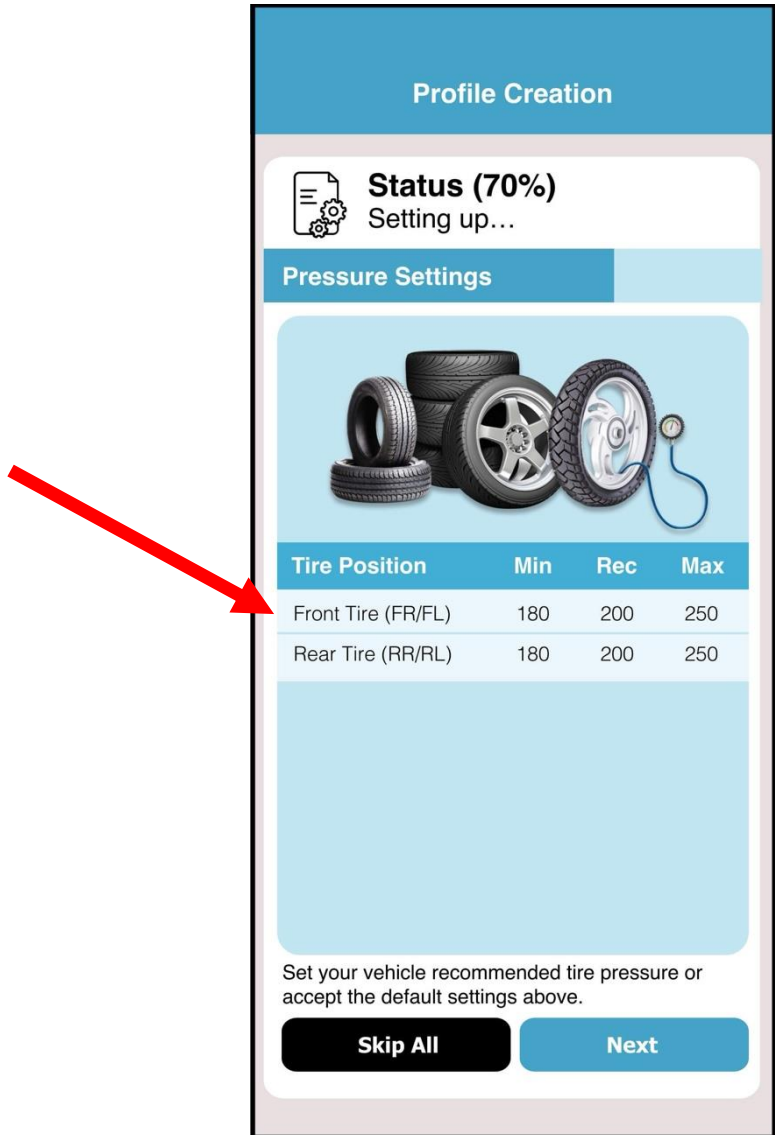

11) Sensors are linked to a QR Code image (FOBO TIRE LITE) from the factory, each sensor is inserted with a battery tab. Unscrew the sensor cover, remove battery tab and install sensor on the tire position as indicated on the battery tab. Perform this with one sensor at a time, continue the same procedure with other three sensors (one at a time).

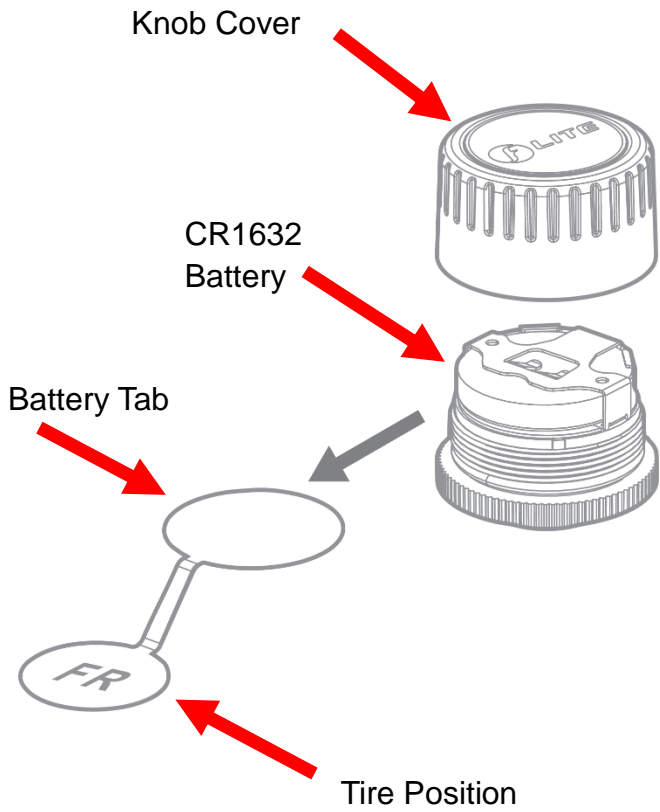

**Profile Creation**

**Status (100%)**  
Setting up...

**Install Sensors**

Please install the sensor into the tire according to the position displayed on the sensor label.

**FL**  
Front Left

**FR**  
Front Right

**RL**  
Rear Left

**RR**  
Rear Right

Once you have done installing the sensor. Press the "Finish" button to complete the installation.

**Finish**

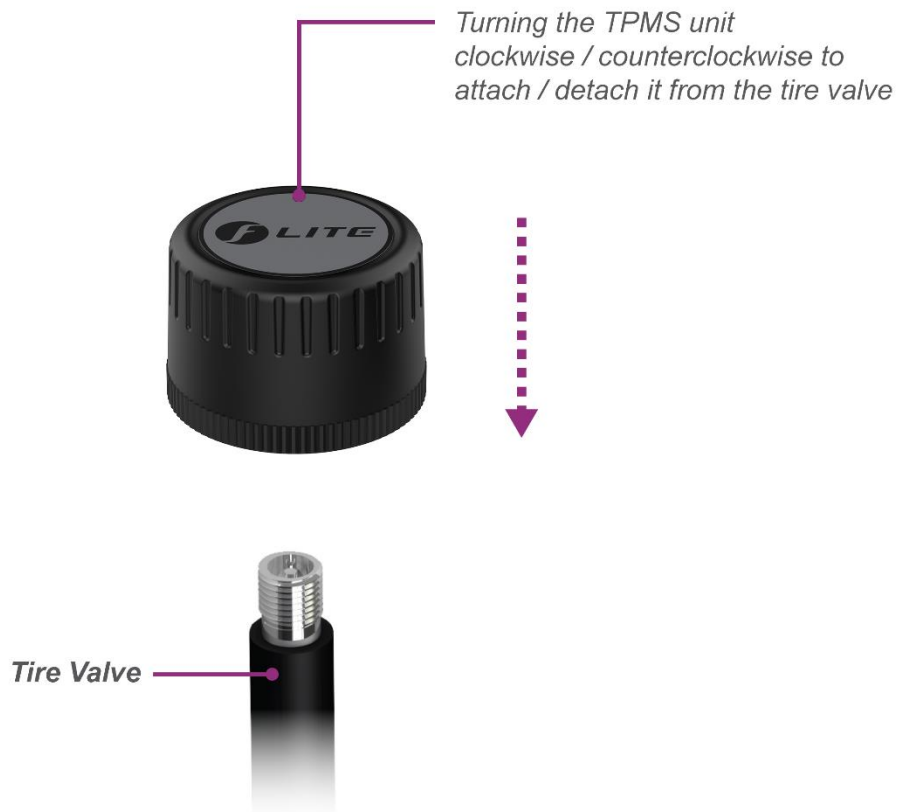

**CAUTION:**

Motor vehicles of all kinds (cars, trucks, motor scooters and motorcycles) come with a very wide array of rims, wheels, and tires, with an even larger choice of aftermarket products. It is impossible for us to test every combination and check the fitment of the FOBO sensor. In some instances, when the FOBO sensor is screwed onto the valve stem, it might extend slightly beyond the face of the rim/wheel. If the rim/wheel comes close to or strikes an object, such as a curb, a pothole, the guide rail for an automatic car wash, or a component on the vehicle, the FOBO sensor or the valve stem itself might become damaged. This can cause the FOBO to provide improper readings or might cause a loss of air pressure. We recommend that you carefully assess the fitment of your rims, wheels, tires and the FOBO on your vehicle. If you have any concerns, consult with your tire shop or auto mechanic. A shorter valve stem might be considered to mitigate the situation.

## 5.3 Setting Up Multiple Users (FOBO Share)

In FOBO TPMS app, you can share your car profile with your family members and friends. You can share your profile with up to 100 users by using the app's FOBO Share function. All that is required is that these other persons download the FOBO TPMS app (they will also need an iOS / Android smartphone with Bluetooth 4.0 that is running on iOS 13 and Android 8.0 or later) on their smartphone and activate the account.

Follow the below steps to share your car profile with other users: -

1. Ensure that the user to be shared (recipient) has downloaded the FOBO TPMS app and activated the account.
2. Ensure that the recipient's smartphone has Bluetooth and Internet connection turned on.
3. On your car status screen, click on the "Settings" icon.

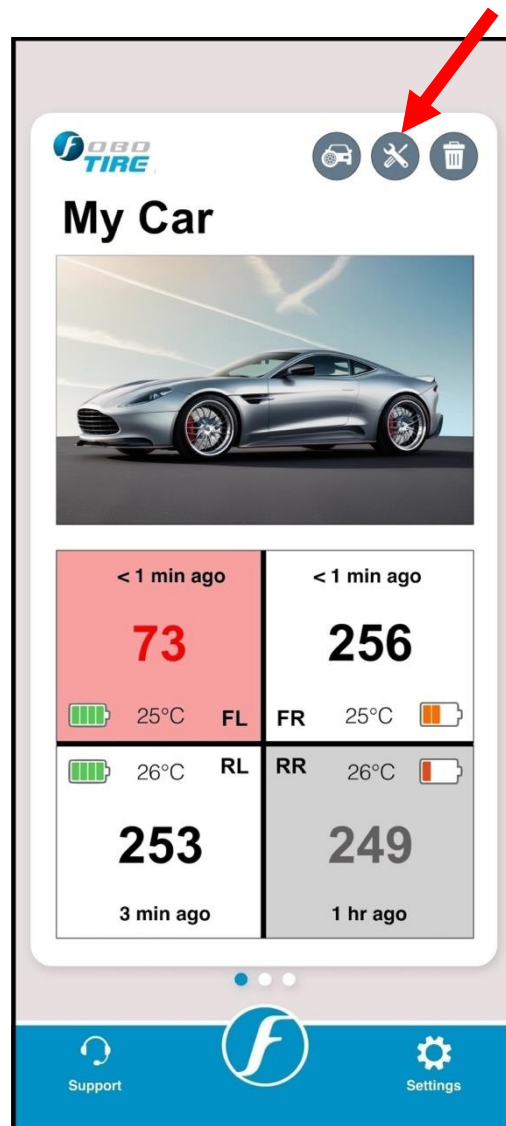

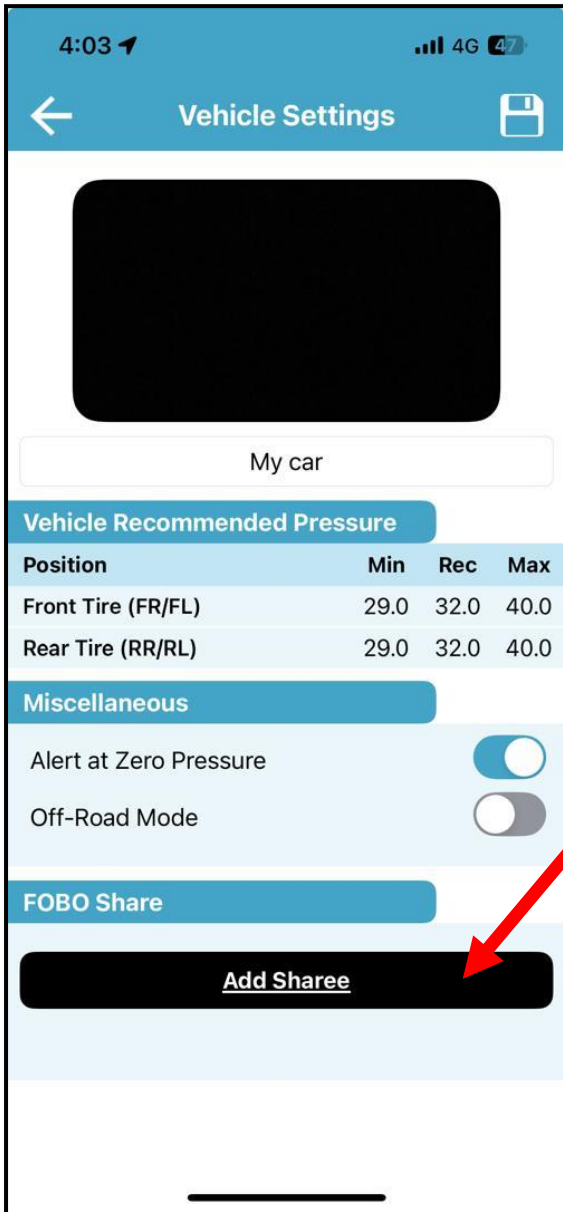

4. Click on the “Add Sharee” button and complete the action by using any of the available option.

5. Once recipient clicks on the link, the shared profile will appear on his / her smartphone under FOBO TPMS app. Sharee will start to receive all the data from shared FOBO TIRE LITE sensors on his/her smartphone, when he / she (Sharee) or Master is within the Bluetooth range of the sensors.

6. Sharee Email will appear under Master Account on the “Vehicle Settings” page.

**NOTE:** Please ensure good Internet connection for FOBO TPMS app to connect to the FOBO cloud server.





Note that shared users will not be able to change settings (name, pressure limits, etc.) on your FOBO TPMS profile using their smartphones. They can only view the readings. At the FOBO TPMS app “Home” page, a shared car profile will depict a “FOBO Share” logo to distinguish a shared car from your own car.

**f** OBD  
**TIRE**

My Wife's Car

**f** SHARE



< 1 min ago	< 1 min ago
<b>73</b>	<b>256</b>
 25°C FL	FR 25°C 
 26°C RL	RR 26°C 
<b>253</b>	<b>249</b>
3 min ago	1 hr ago

Support **f** Settings



## 5.4 Disable and Enable Sensor

You may want to disable a sensor in the app due to physically missing sensor or damaged sensor. Disabling and releasing the missing or damaged sensor in the app will stop monitoring the sensor.

### To Disable a Sensor:

- 1) Long press on the box corresponding to the tire position you want to disable.
- 2) Press on the "Disable" option.
- 3) Press "Confirm" to proceed with the action.

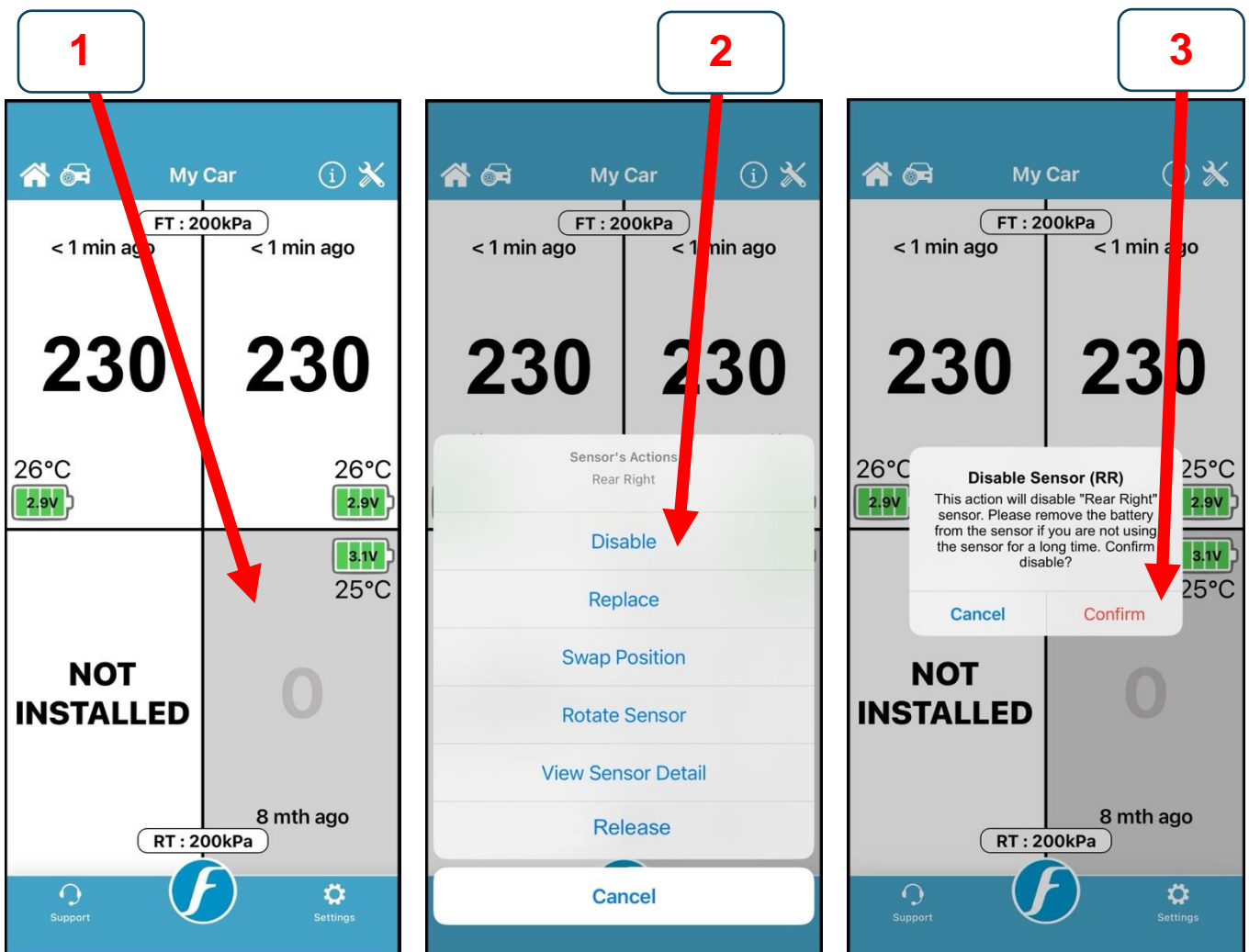

**Note:** Please ensure you are connected to the Internet otherwise app will not perform the action and it will display an error message. You can enable back the same sensor by following the same process.



## 5.5 Release and Install Sensor

### To Release a Sensor:

- 1) Long press on the box corresponding to the tire position you want to release.
- 2) Press on the "Release" option.
- 3) Press "Confirm" to proceed with the action.

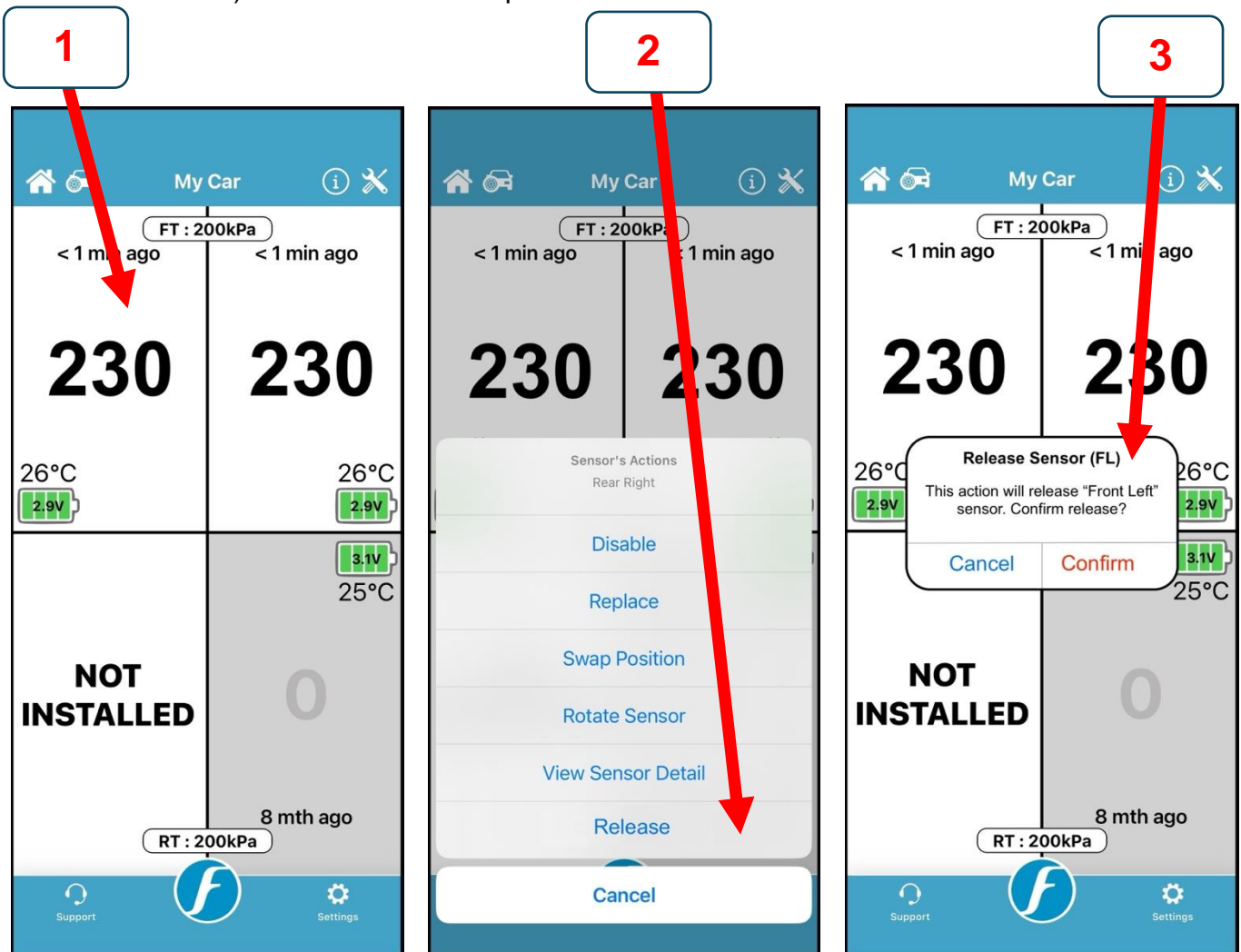

**Note:** Please ensure you are connected to the Internet otherwise app will not perform the action and it will display an error message.

## To Install a Sensor:

- 1) Long press on the box corresponding to the tire position you want to install. This would be the box with the text “Not Installed”.
- 2) Press “Install”.
- 3) Follow the instructions and press on “Process”, you will see pressure readings inside the box corresponding to the installed tire position.

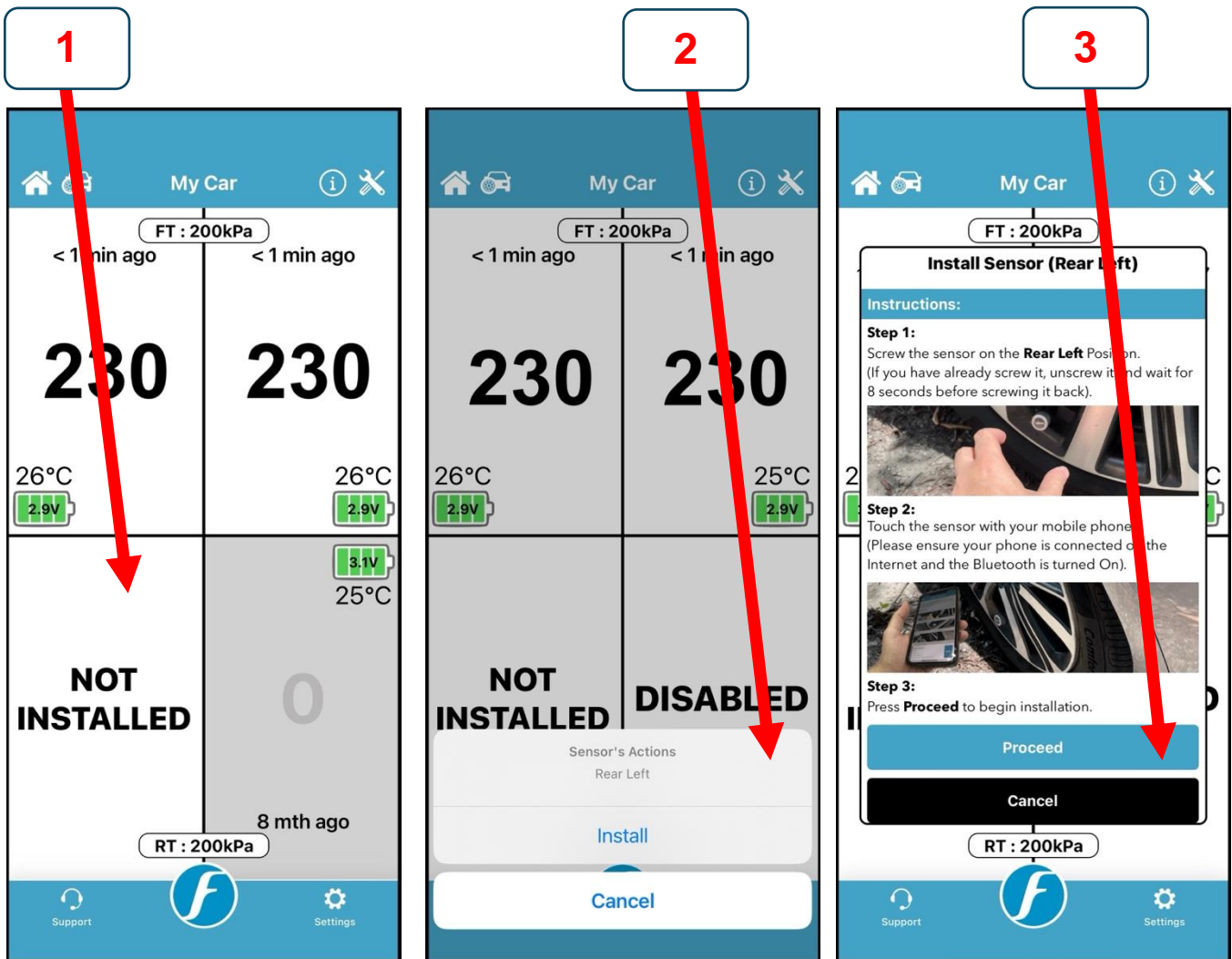

**Note:** Please ensure you are connected to the Internet otherwise app will not perform the action and it will display an error message.

## 5.6 Swap and Rotate Sensor

### To Swap a Sensor:

- 1) Long press on the box corresponding to the tire position you want to swap position.
- 2) Press on the "Swap Position" option.
- 3) Choose the new position of a sensor from the list.

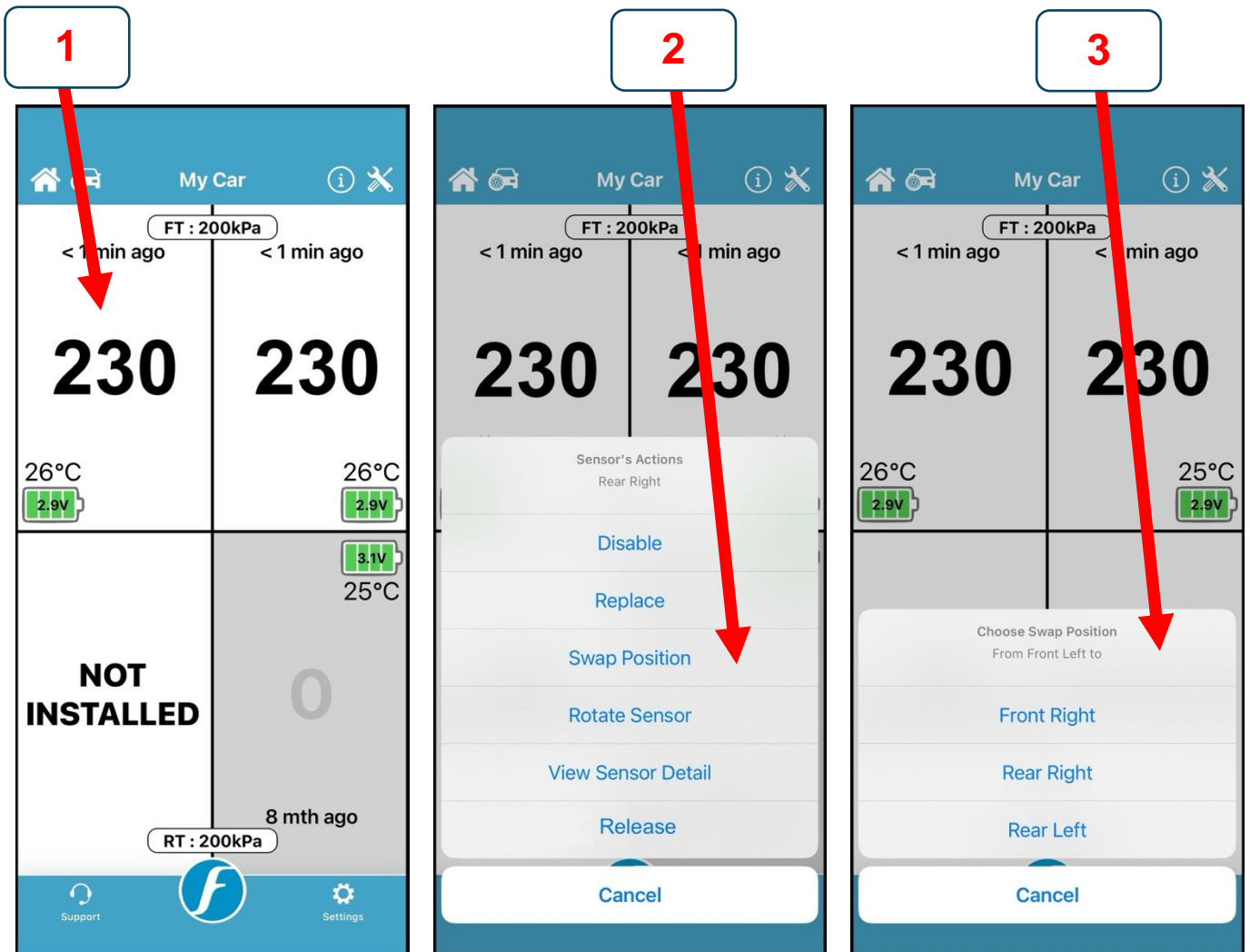

**Note:** Please ensure you are connected to the Internet otherwise app will not perform the action and it will display an error message.

## To Rotate Sensor:

It is good practice to rotate your tire positions regularly to balance the thread wear of your tires, usually swapping the front tires with the rear tires. FOBO TPMS is designed to conveniently set the sensors to their correct tire position in the app after you swapped your tires on your car. You do not need to physically remove the sensors.

- 1) Long press on any of the tire position box.
- 2) Press on the "Rotate Sensor" option.
- 3) Touch the "Front Right" sensor with your phone and press OK to proceed with scanning. Once done with the "Front Right" position, continue the same action for the rest of the tire position.

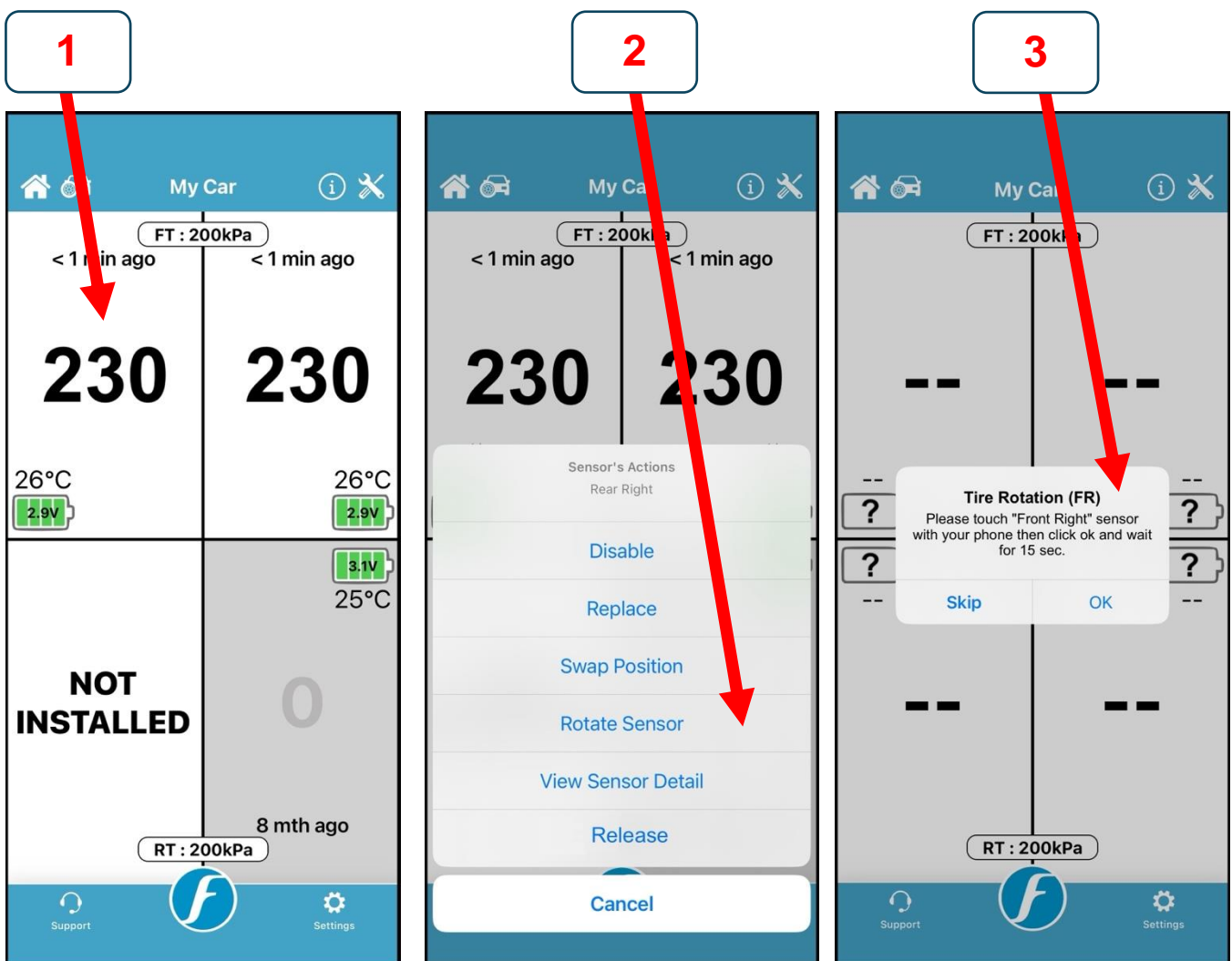

**Note:** Please ensure you are connected to the Internet otherwise app will not perform the action and it will display an error message.

## 5.7 Transfer FOBO TIRE LITE to another User

Before passing on your FOBO TIRE LITE set to another user, you will have to remove the system from your FOBO account.

### To Remove Profile:

- 1) To remove the system from your account, press on the delete  icon at top right corner of your car profile.
- 2) You will be prompted with a message "This action will delete the <Profile Name> profile. Confirm delete?" to remove the system from your account. Confirm your action by pressing on the "Confirm" button.

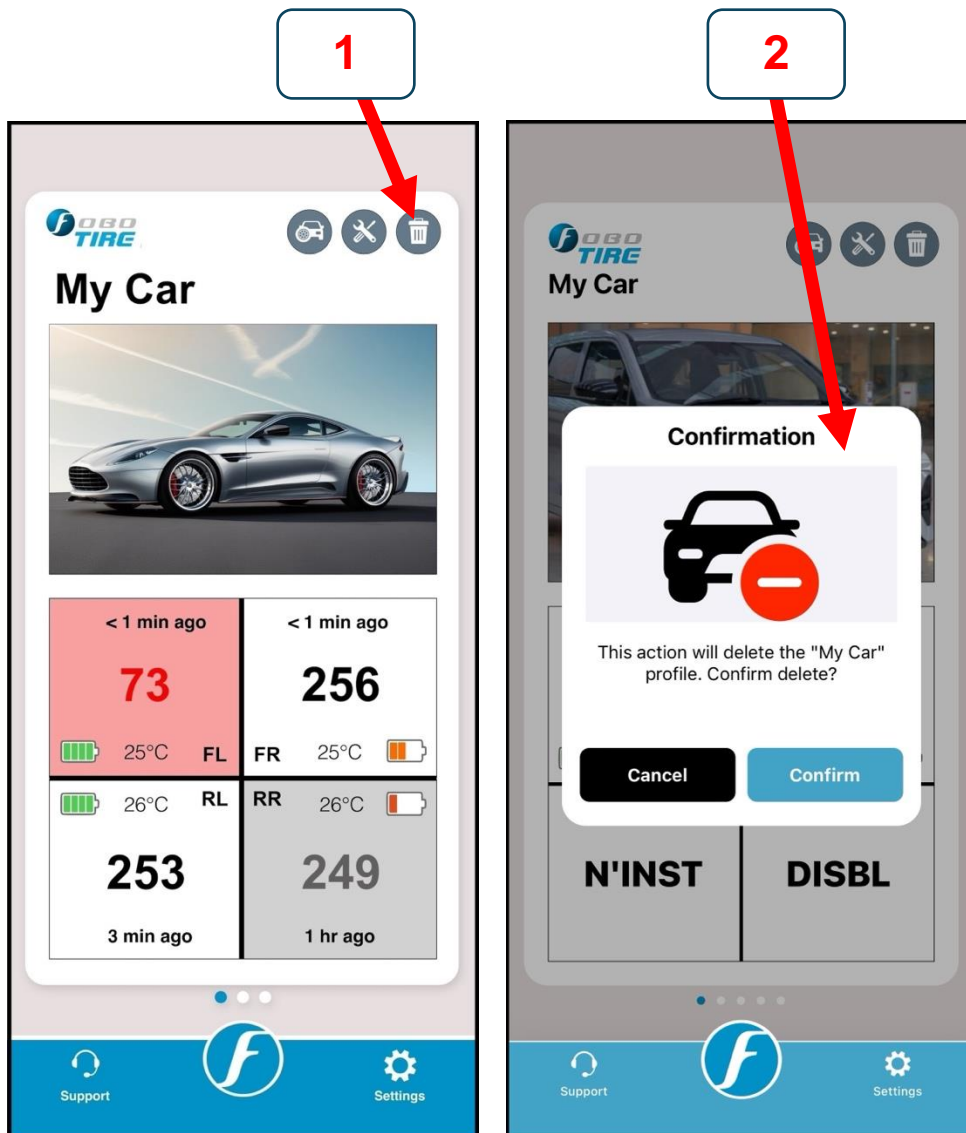

**Note:** Please ensure you are connected to the Internet otherwise app will not perform the action and it will display an error message.

## 5.8 Gauge Pressure

For users who wish to retain “Gauge Pressure Reading”, the FOBO TPMS app has a Gauge Pressure feature, adjusted to local altitude using cell towers or individual phone barometer if available. This Gauge Pressure button can be accessed from the app.

### To Turn On/Off the Gauge Pressure:

- 1) Press on the “Settings” tab located at the bottom right of the “Home” page.
- 2) Turn On / Off “Gauge Pressure by using the toggle button.

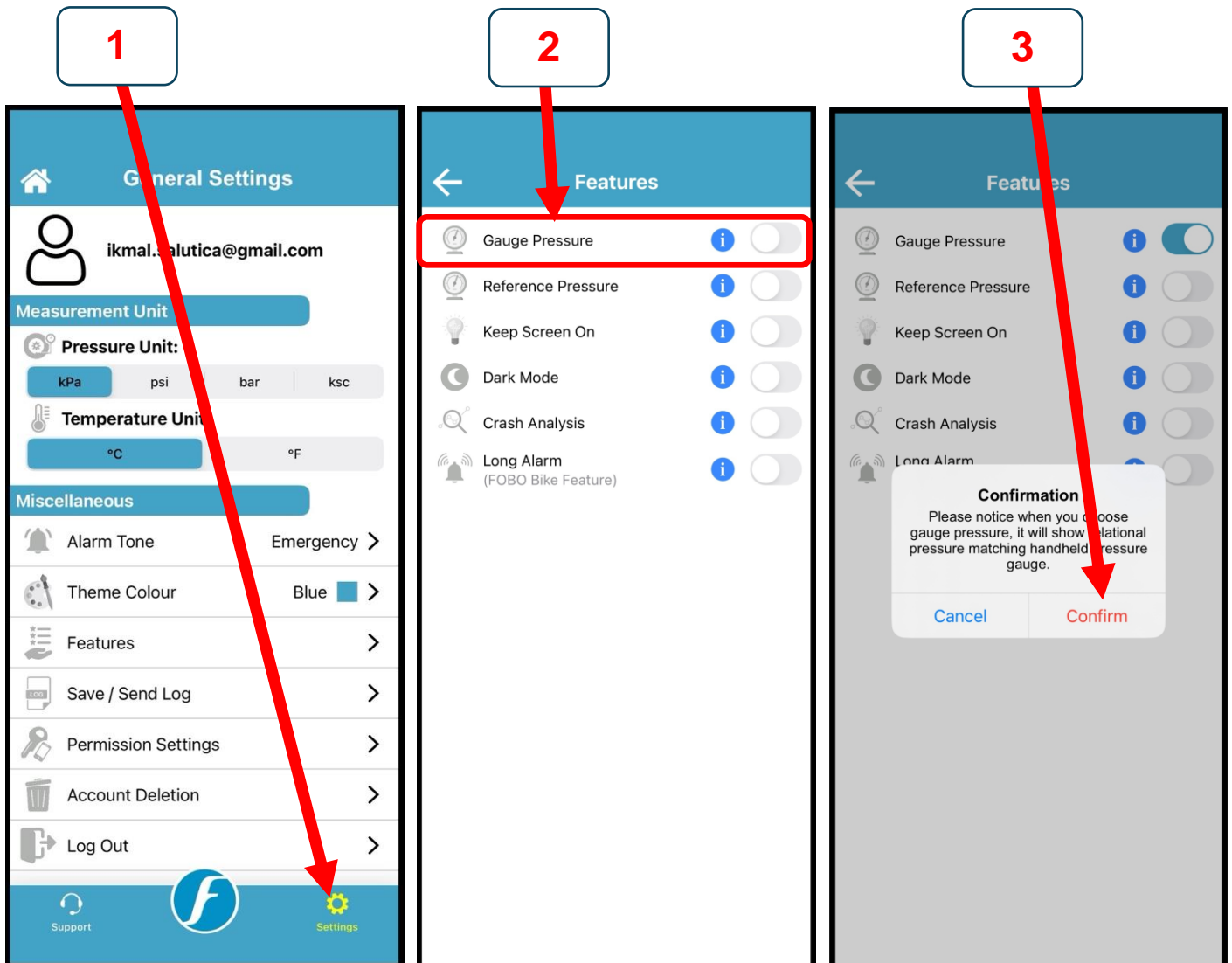

## 5.9 Off-Road Mode

### To Turn On/Off the Off-Road Mode:

- 1) At the “Home” page, press on the “Settings” icon.
- 2) At the “Vehicle Settings” page, look for “Off-Road Mode” option and use the toggle button to turn On/Off the “Off-Road Mode” feature.

1

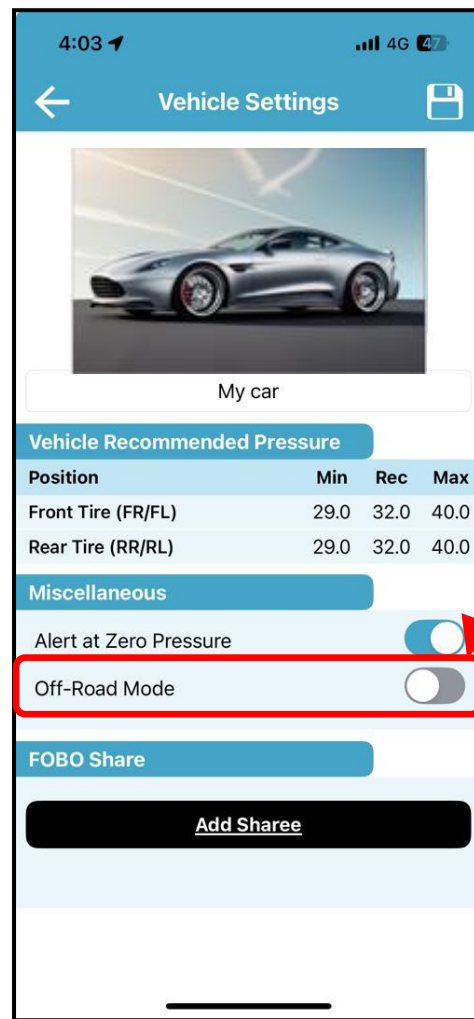
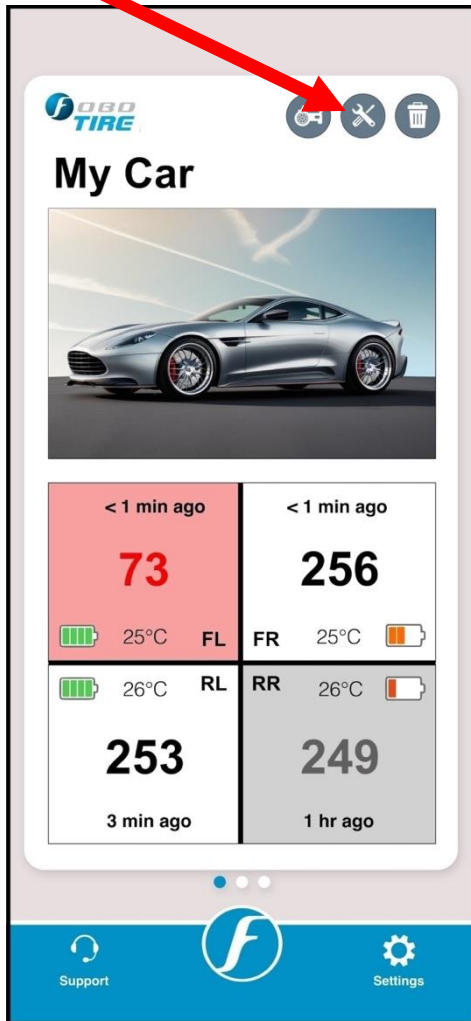

2



- Set new recommended pressure for front and rear axle and press on the “Save” icon at top right corner. This would be your new pressure settings for “Off-Road” mode.

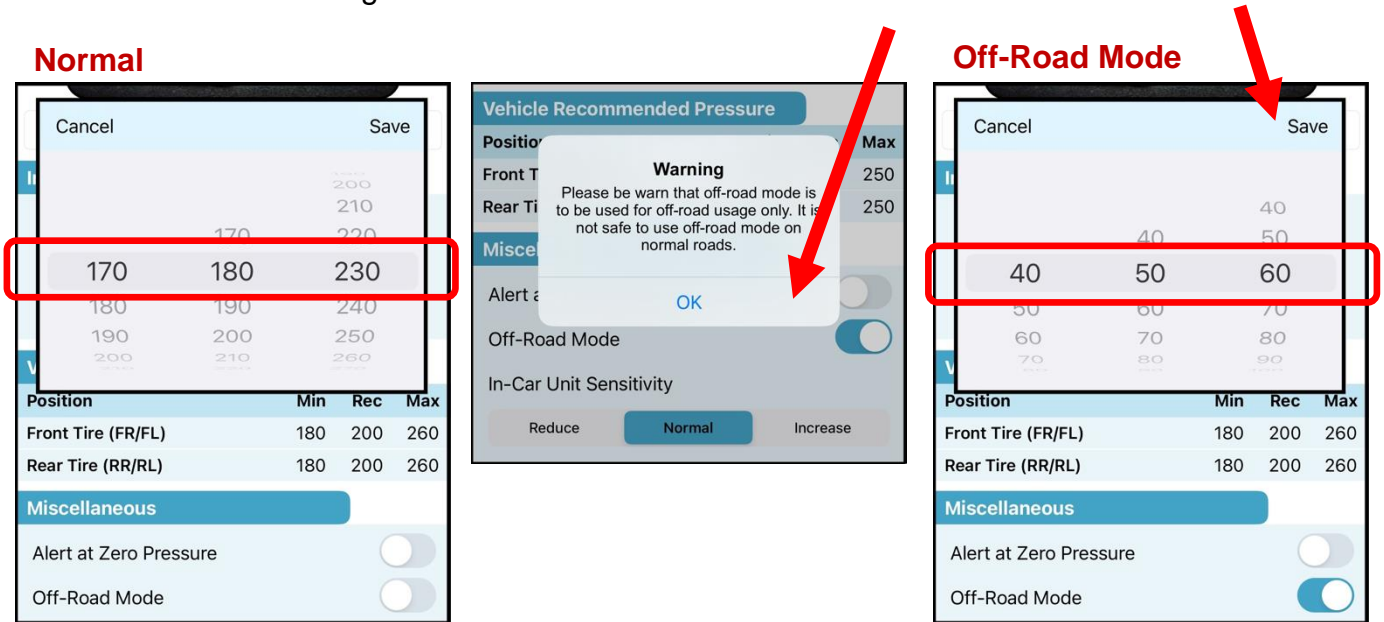

## CAUTION:

**Do not use Off-Road mode on normal roads, it's only to be used for Off-Road activities where lower tire pressure is required.**

## 5.10 Tire Inflation/Deflation

In order to Inflate/Deflate the tire user just need to unscrew the sensor, inflate/deflate tire and then screw back the sensor on tire valve. User does not need to release or disable the sensor.

## 5.11 Reference Pressure

Reference pressure is a temperature-compensated tire pressure referenced back to a standard temperature of 20 degree Celsius. This is useful and serves as a guide for the user to decide on the approximate amount of air needed to inflate the tire during hot season or immediately after a long ride

The reference pressure reading is located near the actual pressure reading in smaller font size. User has an option to show / hide the reference pressure reading by going to the “Settings” tab > “Features” > Toggle the “Reference Pressure” switch as shown below.



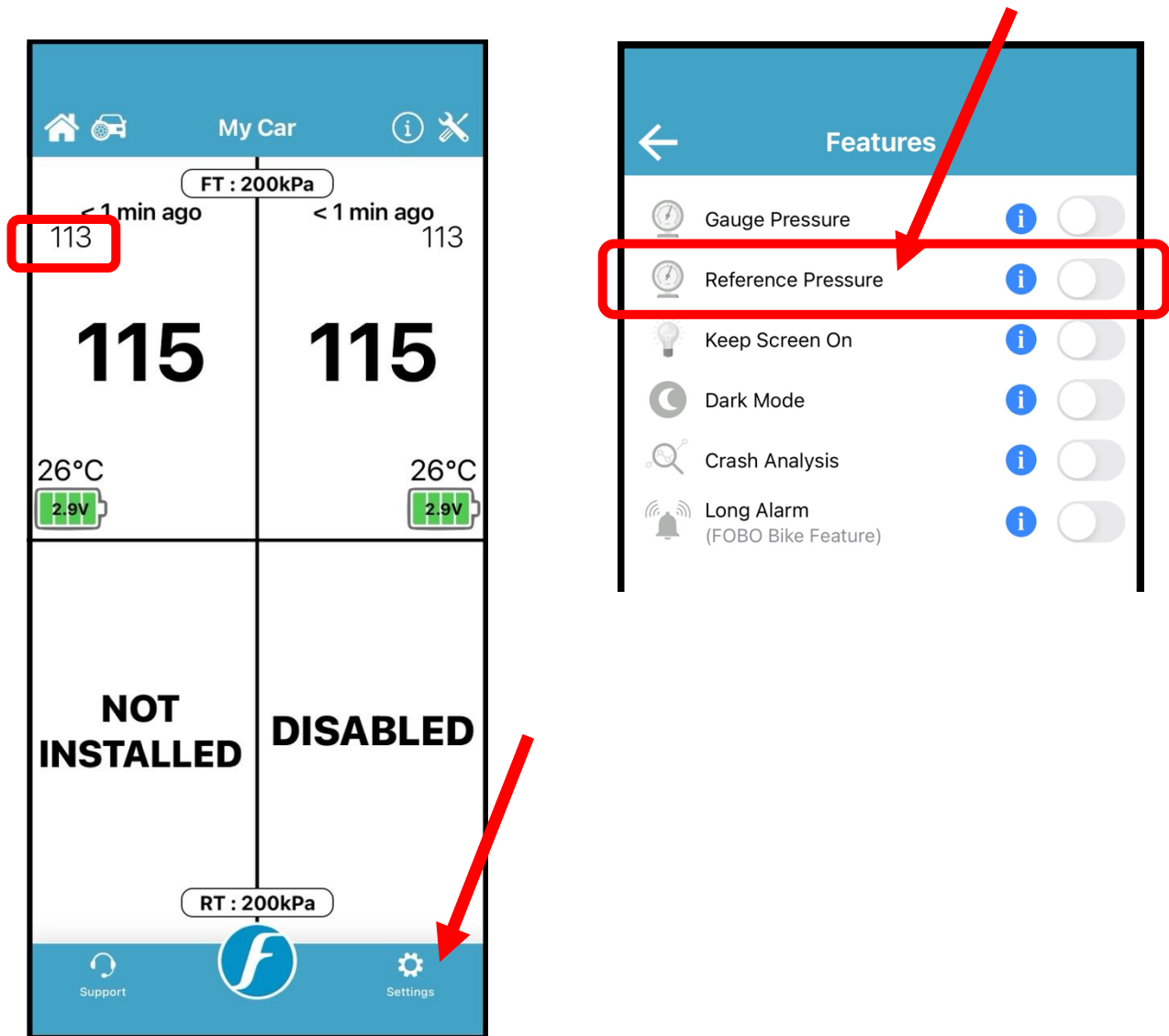

## 5.12 Overlay Services (Android Only)

“Overlay services” feature is an effective approach which helps the users to get the latest pressure, temperature, and battery readings just by a single click on the FOBO overlay icon which is displayed on the mobile home screen without the need of going into the FOBO TPMS app. User can use any other app in the foreground with live FOBO readings displayed on the screen. **This feature is only available on Android devices.**

To turn on the Overlay Service:

- 1) Open the FOBO TPMS app.
- 2) Press on the “Settings” tab (wheel icon at the bottom right of screen) on the “Home” page of the FOBO TPMS app.
- 3) Press on the “Features”.

- 4) Turn on the “Overlay Service”.
- 5) Upon turning on the Overlay Service FOBO overlay icon will appear on the screen.
- 6) Press on the FOBO overlay icon to get the pressure, temperature and battery readings.

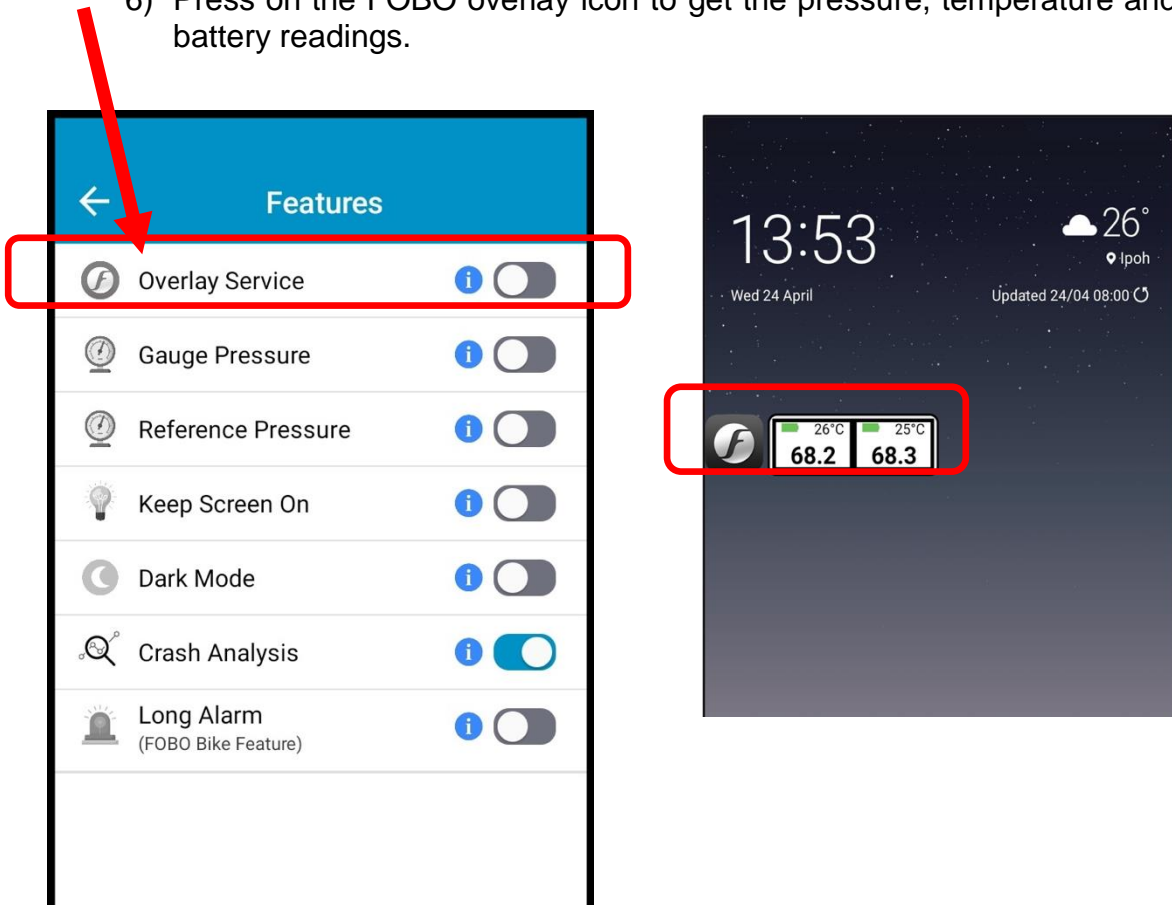

## 5.13 Dark Mode

Dark Mode is a display setting for user interfaces that replaces the standard light background with a darker background, with light-coloured text and UI elements. This mode is designed to reduce eye strain in low-light environments, conserve battery life on devices with OLED screens, and provide a visually appealing alternative to the traditional light mode.

### To Turn On/Off the Dark Mode:

- 1) Press on the “Settings” tab (wheel icon at the bottom right of screen) on the “Home” page of the FOBO TPMS app.
- 2) Press on the “Features”.
- 3) Turn On/Off the “Dark Mode” feature.

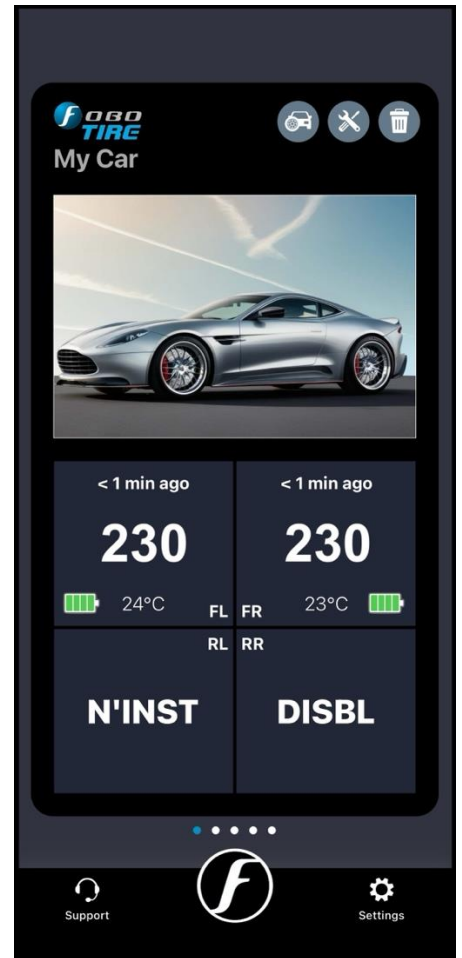
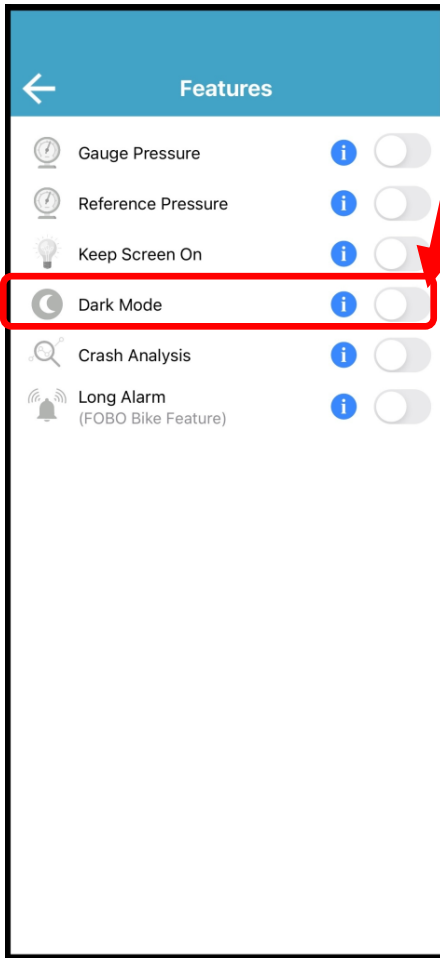

## 5.14 Spare Tire Sensor Installation

You can install FOBO TIRE LITE sensor on the spare tire, this is to ensure that you have an operational tire when you really need it.

### To Install Spare Tire:

- 1) Press on the "Spare Tire" icon at the top right corner of the "Home" page.
- 2) Press the Add "+" button.
- 3) Key in details, such as the spare tire name and pressure settings. Press on the "Save" icon after entering all the details.

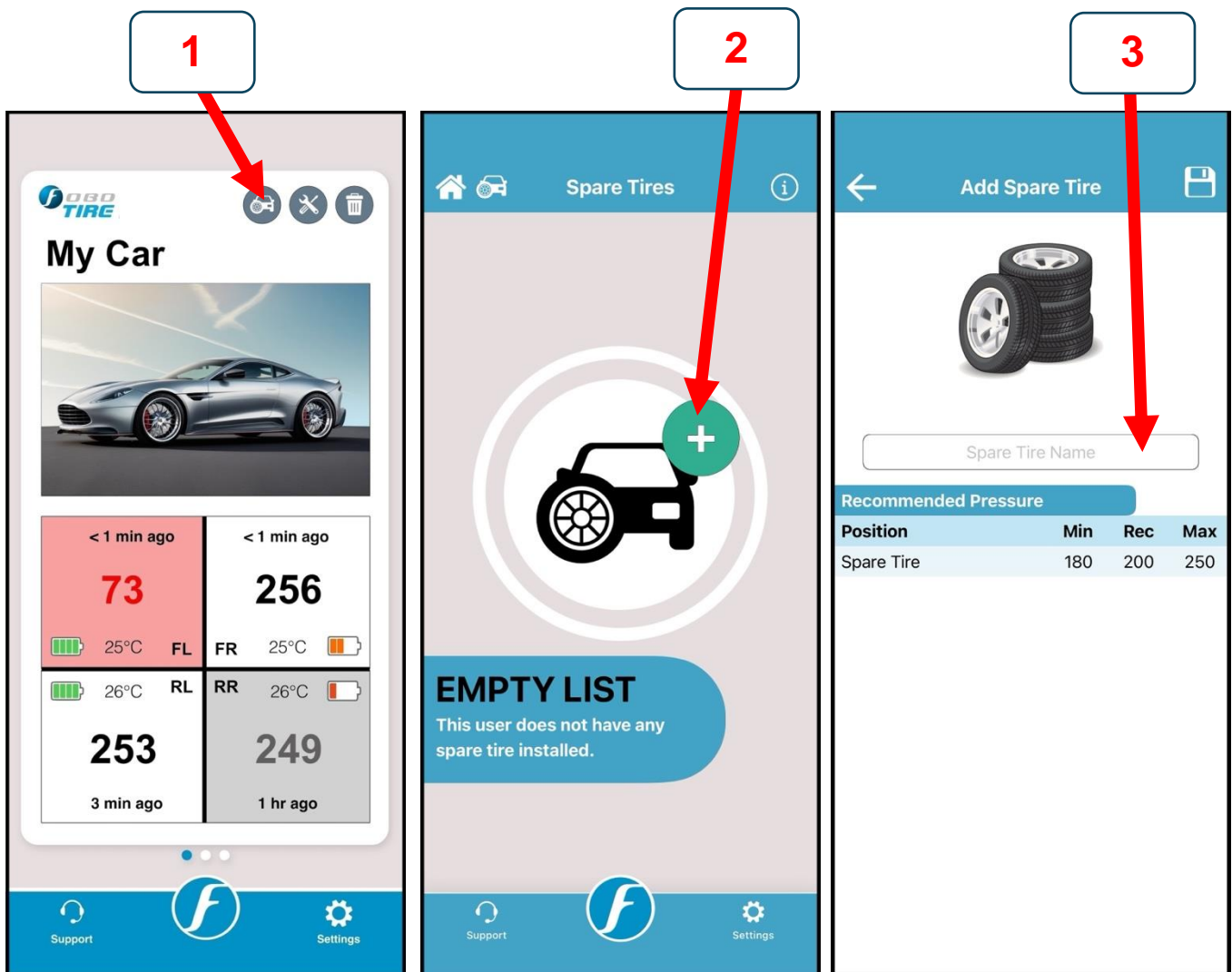

- 4) Follow the on-screen instructions to install a sensor and press the "Proceed" button.
- 5) After a successful installation, your spare tire sensor will appear in the "Spare Tires" list page.
- 6) At the "Vehicle Details" page, you can access the "Spare Tires" page by either pressing the car icon, or simply by scrolling the screen.

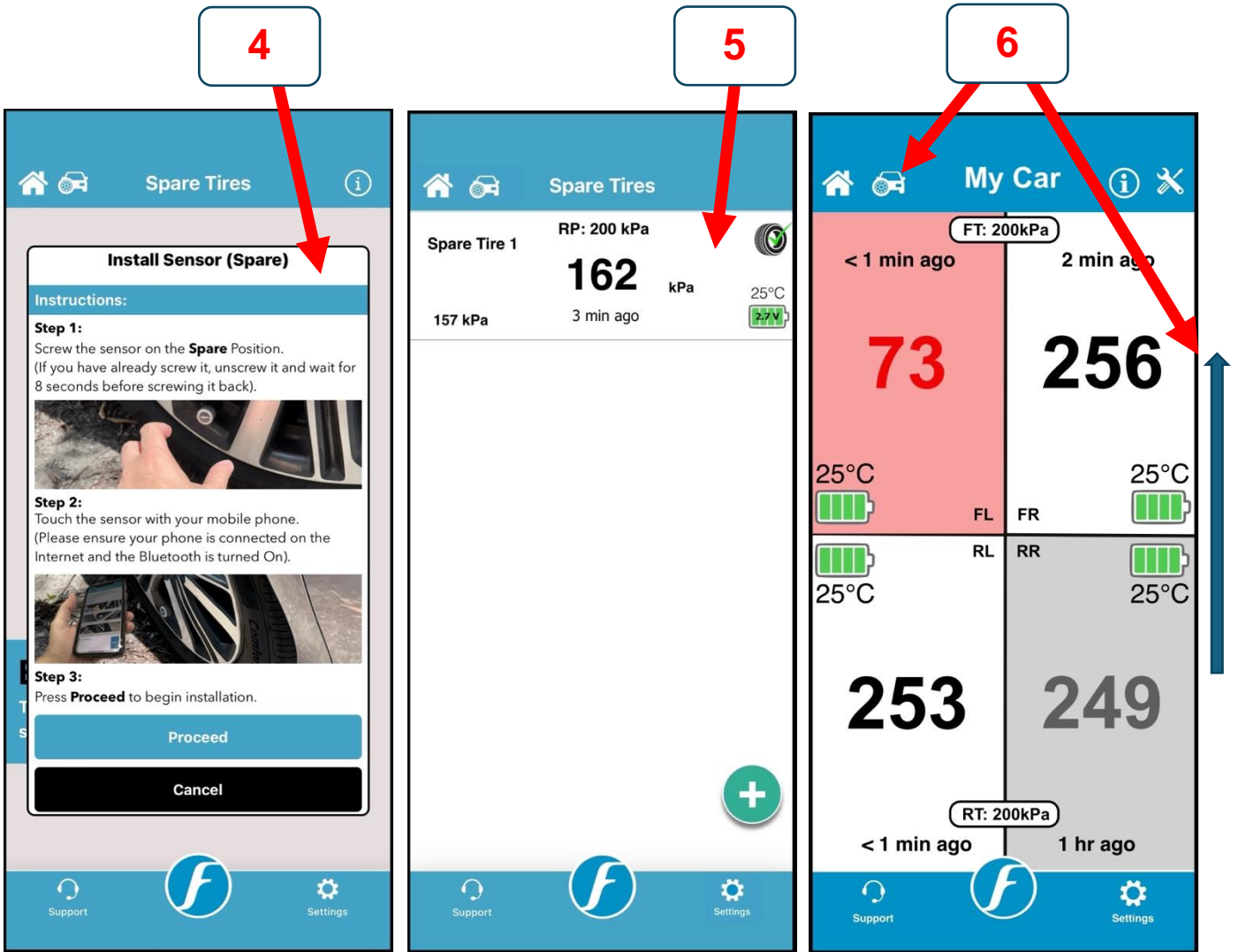

**Note:** Please ensure you are connected to the Internet otherwise the app will not be able to perform the "Spare Tire" installation action and it will display an error message.

## 5.15 General Settings Page

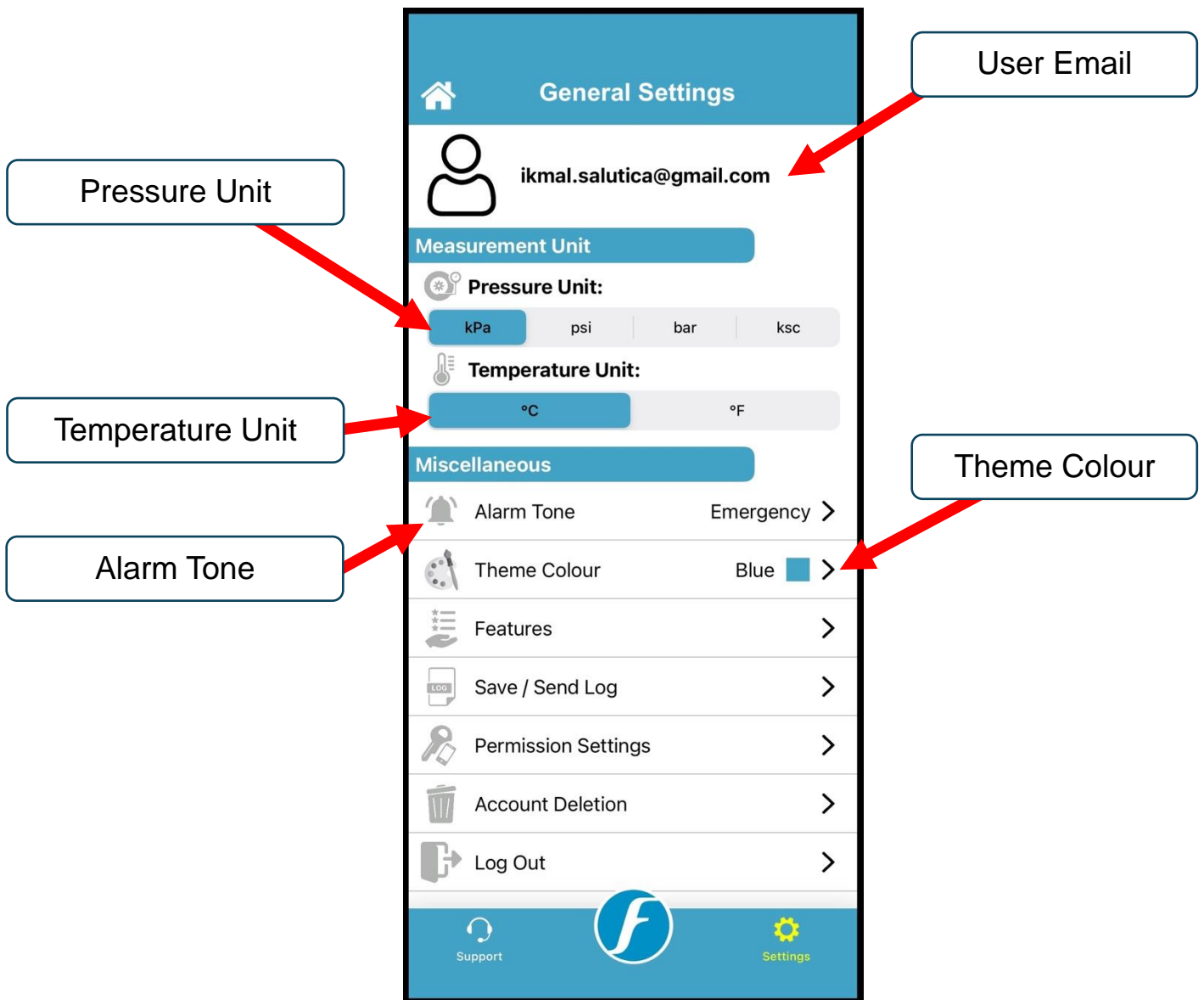

**Pressure Unit** Select pressure unit (kPa, psi, bar, ksc).

**Temperature Unit** Select temperature unit (°C, °F).

**Alarm Tone** Select alert ringtone type.

**Theme Colour** Select theme colour.

**Features** Open up to show additional features.

**Permission Settings** Display list of permissions require for the app.

**Account Deletion** Remove your account from the FOBO database entirely.

**Log Out** Log out from this account.

## Features Page

You can learn information regarding each feature by pressing the blue coloured (i) information icon beside the feature name.

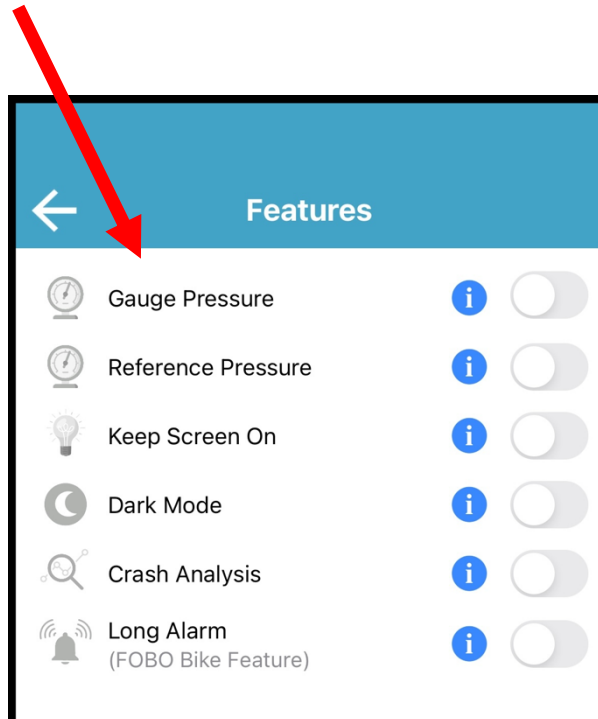

### Gauge Pressure

Refer to “Gauge Pressure” section of this User Manual.

### Reference Pressure

A temperature-compensated tire pressure referenced back to a standard temperature of 20 degree Celsius.

### Keep Screen On

Keep the screen on when app is running in the foreground.

### Dark Mode

Change the app display to Dark Mode.

### Crash Analysis

Send anonymous crash report to app developer.

## 5.16 Theme Colour

For users who wish to change the app theme colour other than the default blue colour can do so by pressing the “Theme Colour” option in the “General Settings” page and select one of the colours that are available in the list.

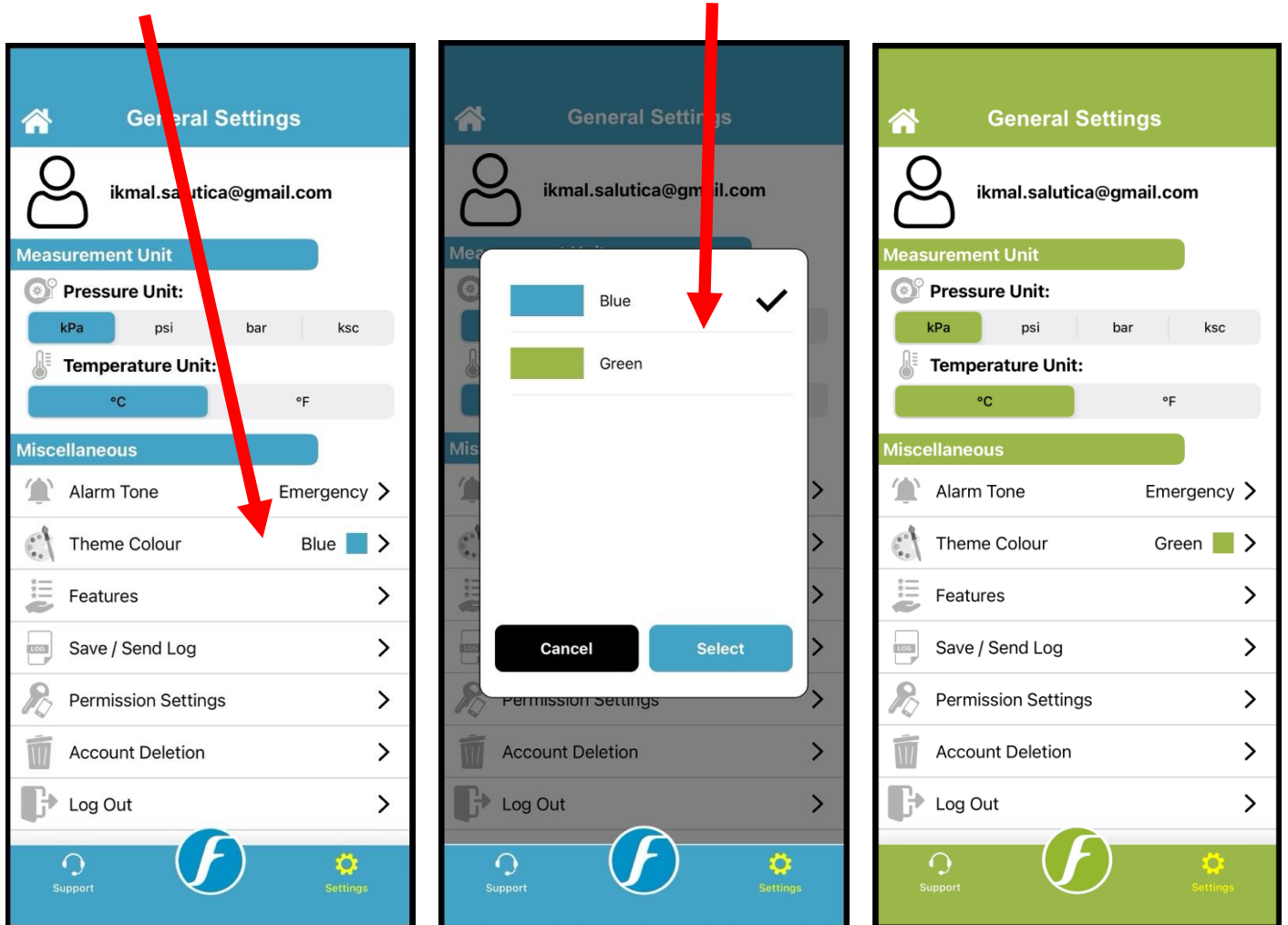



## 5.17 Vehicle Settings Page

At the “Vehicle Settings” page, users can do the following actions:

The screenshot shows the 'Vehicle Settings' page on a mobile app. The page includes a car image, a table for recommended tire pressures, and toggle switches for 'Alert at Zero Pressure' and 'Off-Road Mode'. A 'Save' button is in the top right, and an 'Add Sharee' button is at the bottom.

Callouts and their corresponding actions:

- Update Vehicle Picture (points to the car image)
- Update Vehicle Recommended Pressure (points to the 'Vehicle Recommended Pressure' header)
- Toggle On/Off Off-Road Mode (points to the 'Off-Road Mode' toggle)
- Add/Remove Email from Viewing Your Profile (points to the 'Add Sharee' button)
- Toggle On/Off Alert at Zero Pressure (points to the 'Alert at Zero Pressure' toggle)

Position	Min	Rec	Max
Front Tire (FR/FL)	29.0	32.0	40.0
Rear Tire (RR/RL)	29.0	32.0	40.0

After you update your vehicle settings, please ensure you press the “Save” button to let the app send the data to the server. Additionally, please ensure you are connected to the Internet otherwise the app will not be able to save your data.

## 5.18 Vehicle Details Page

At the “Vehicle Details” page, users can do the following actions:

The screenshot shows the 'My Car' page with four sensor cards. The top-left card (FL) shows a pressure of 73 and a temperature of 25°C. The top-right card (FR) shows a pressure of 256 and a temperature of 25°C. The bottom-left card (RL) shows a pressure of 253 and a temperature of 25°C. The bottom-right card (RR) shows a pressure of 249 and a temperature of 25°C. A red box highlights the RR card. Callouts point to the 'Spare Tires' icon, the 'i' icon, the 'wrench' icon, the 'Support' icon, and the RR card. An inset 'Instruction' dialog shows a hand long-pressing the FR card, with text: "Long Press" the individual sensor box for more actions. A list of actions is provided in a separate callout.

Open the “Spare Tires”

Open the Instruction Dialog

Open the “Vehicle Settings”

Go Back to the Previous

**Instruction**

FL FR  
RL RR

“Long Press” the individual sensor box for more actions.

OK

“Long Press” to Reveal the Following Sensor Actions:

- 1) Disable/Enable Sensor
- 2) Replace Sensor
- 3) Swap Sensor Position
- 4) Rotate Sensor
- 5) View Sensor Detail
- 6) Release Sensor

## 5.19 Sensor Graph

The Sensor Graph is a feature that allows you to visualize your tire pressure and temperature in a line graph form. To view the Sensor Graph:

- 1) Long press on the desired sensor position (FR, FL, RR or RL).
- 2) Press on the “View Sensor Detail” option.
- 3) Scroll all the way down.

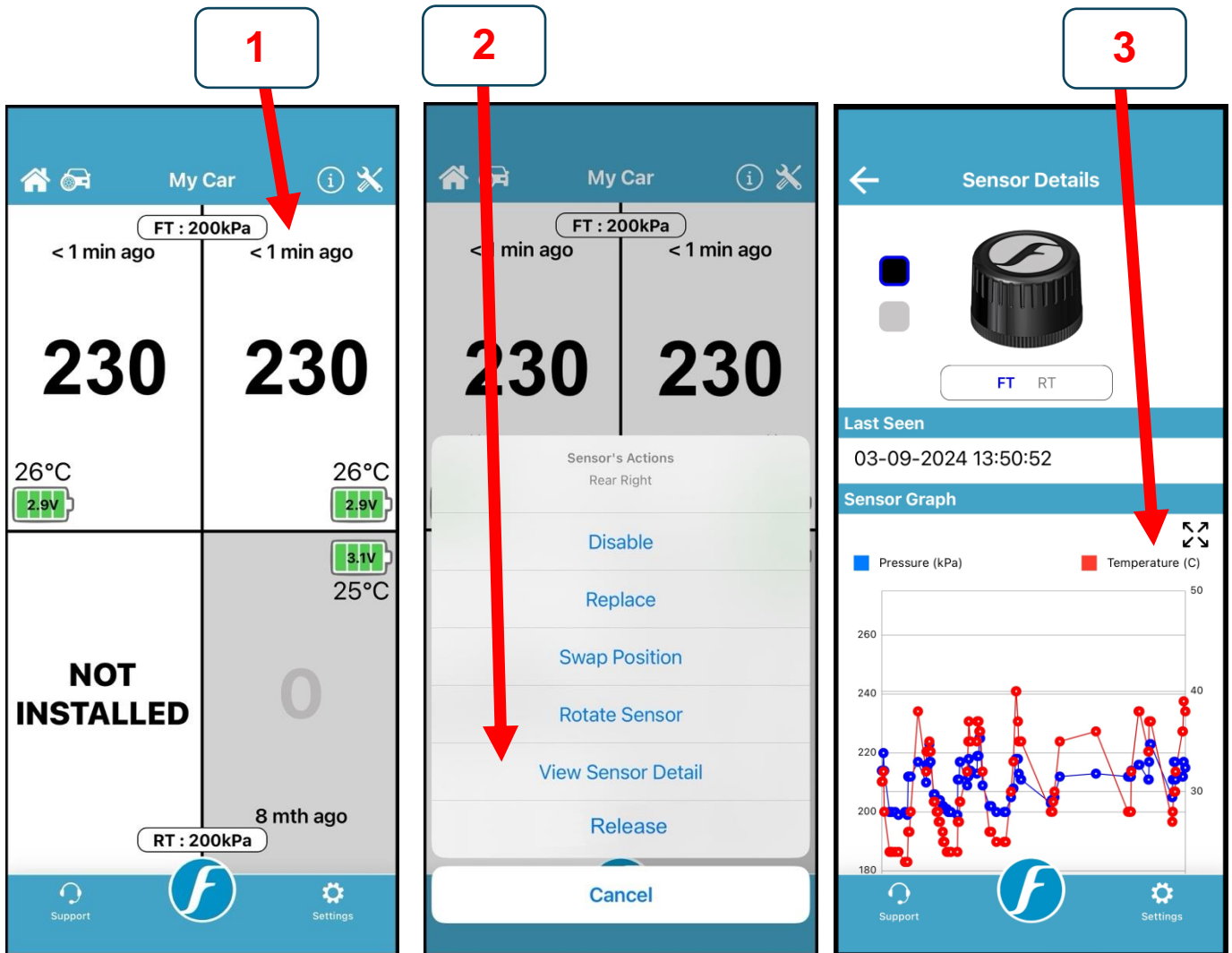

The graph data is originated from your sensor logs. If your sensor logs are empty, or you have recently cleared the logs, or log out from your account, the Sensor Graph will not appear and instead you will see a text displaying “No chart data available”.

The pressure line will be displayed in **BLUE** colour while the temperature line will be shown in **RED** colour. On the left is the pressure labels, on the right is the temperature labels, and at the bottom is the date and time labels.

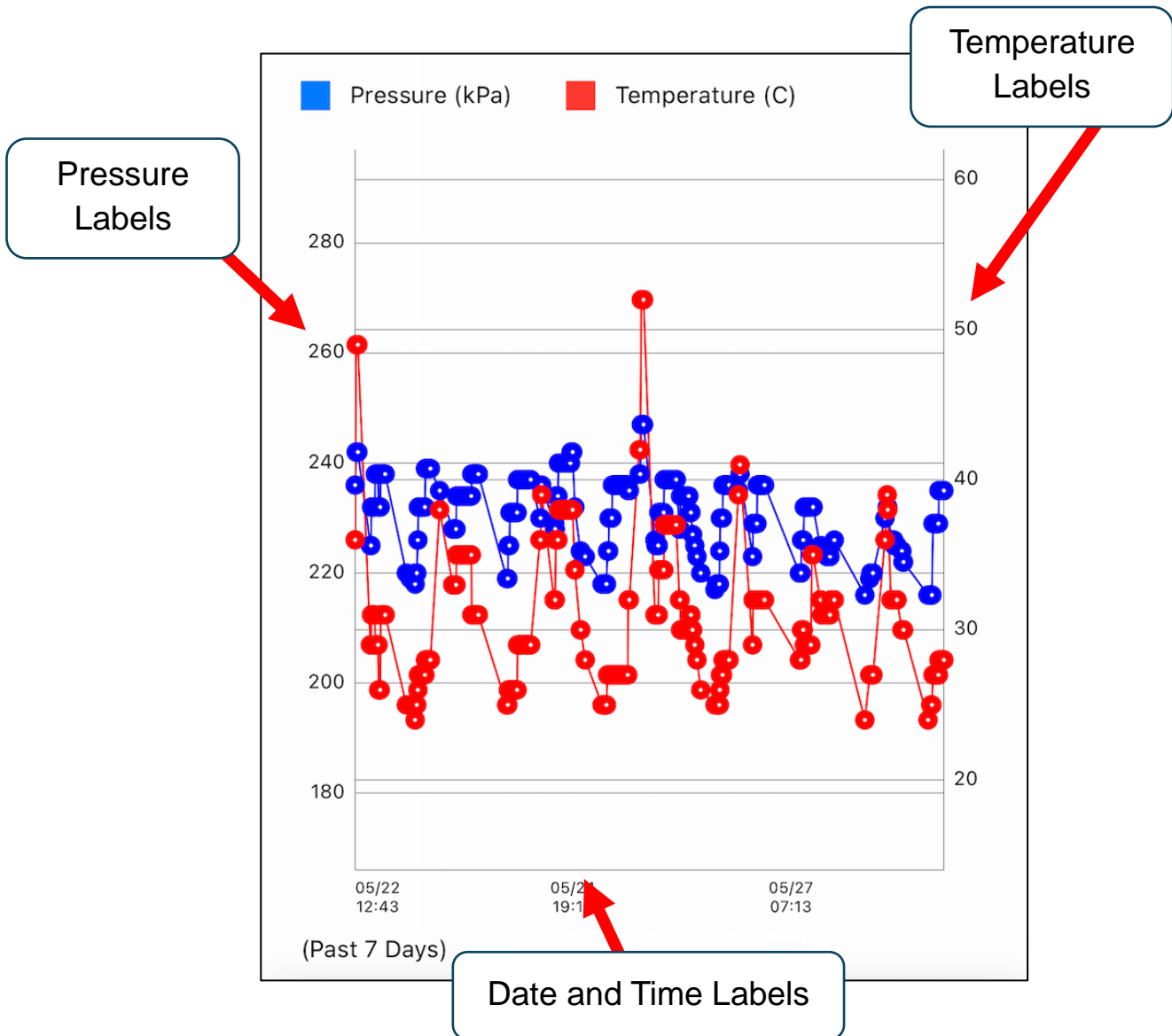

The Sensor Graph will display data from the past 7 days.

1. To zoom in into the graph, “un-pinch” your fingers over the graph.
2. To display the pressure and temperature of a specific graph point, press on any of the blue / red point. An orange vertical line will appear to indicate the data selected is belonging to which date and time.

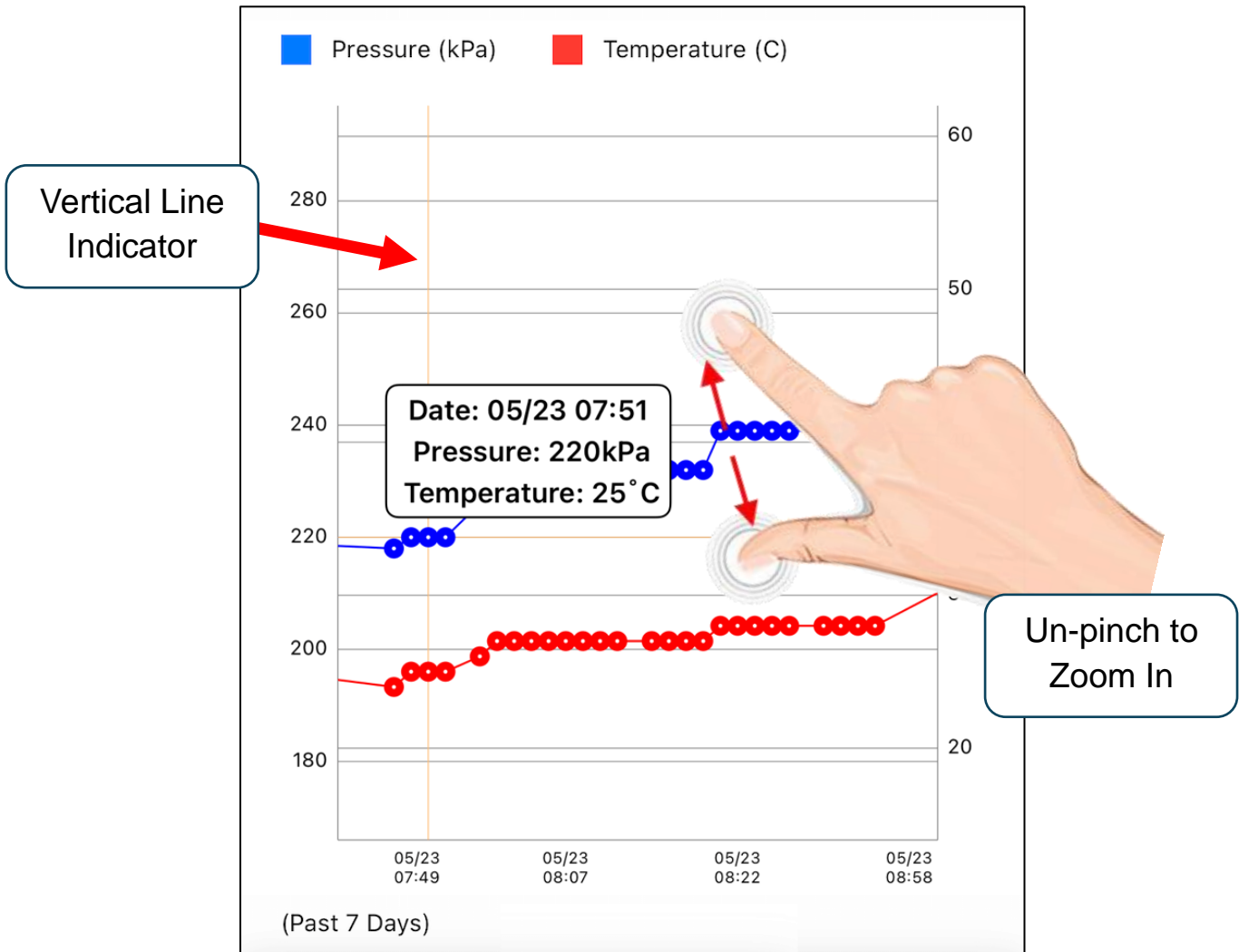

## 5.20 Sensor Firmware Upgrade

FOBO TPMS app also allows you to upgrade FOBO TIRE LITE sensor firmware. Follow the below steps to upgrade sensor firmware:

1. Long press on the desired sensor position (FR, FL, RR or RL).
2. Press on the “View Sensor Detail” option.
3. On the “Sensor Details” page, press the “Upgrade” button.
4. Read and follow the instructions carefully on the next page.

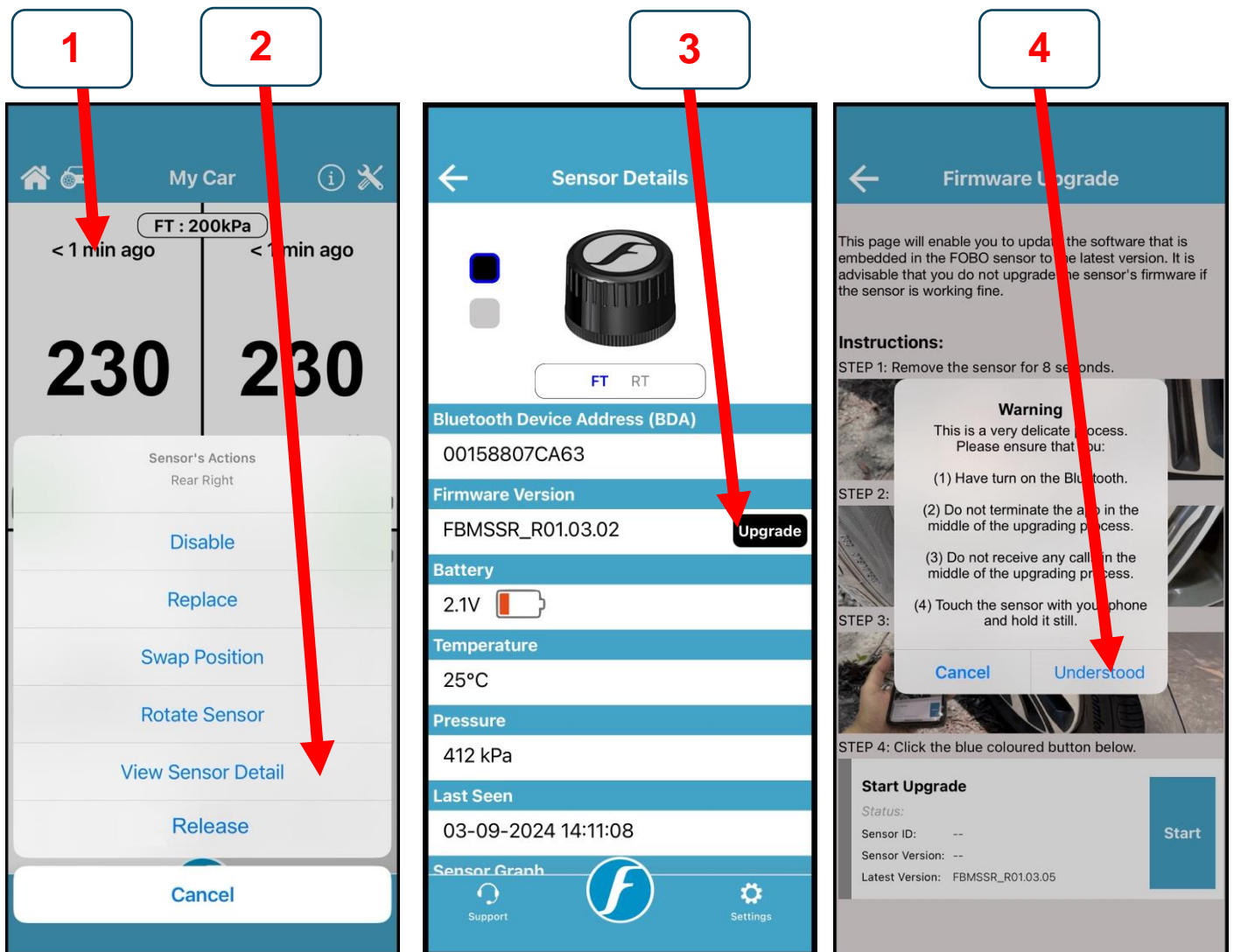

**Note:** Please ensure the sensor has sufficient battery (green colour), otherwise, the firmware upgrading process will fail when the battery is depleted.

On the “Firmware Upgrade” page, press the “Start” button to initiate the firmware upgrade process.

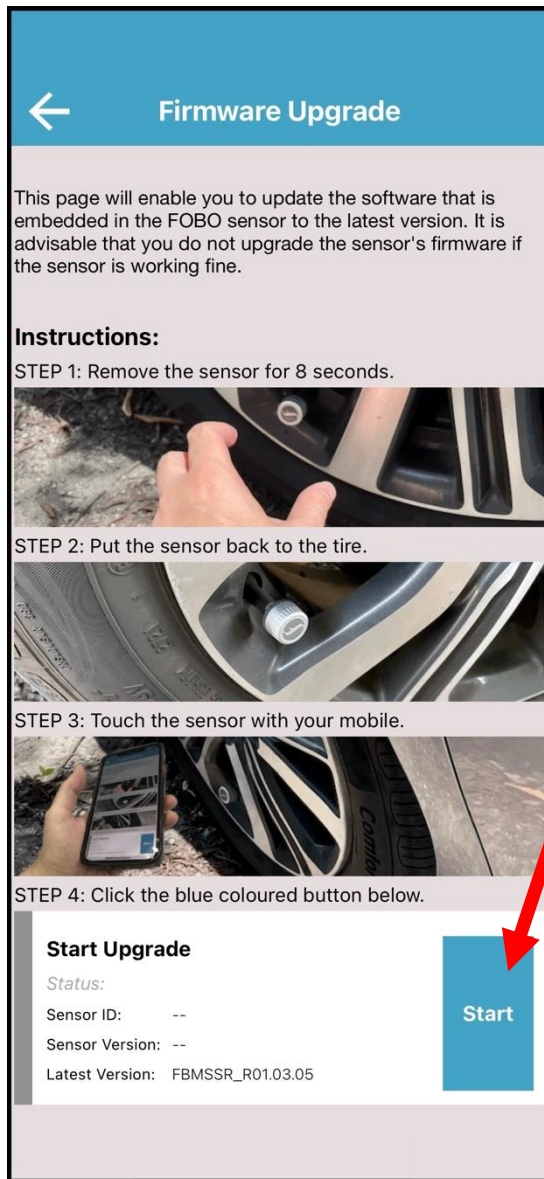

**Note:** If there is no upgrade available then the app will display a message “The firmware version is the latest version.”

## 5.21 Support Page

FOBO TPMS app provides in-app “Help Centre”, “Quick Links” and “Report an Issue” services. In the event any issue arises, feel free to use any option to find help.

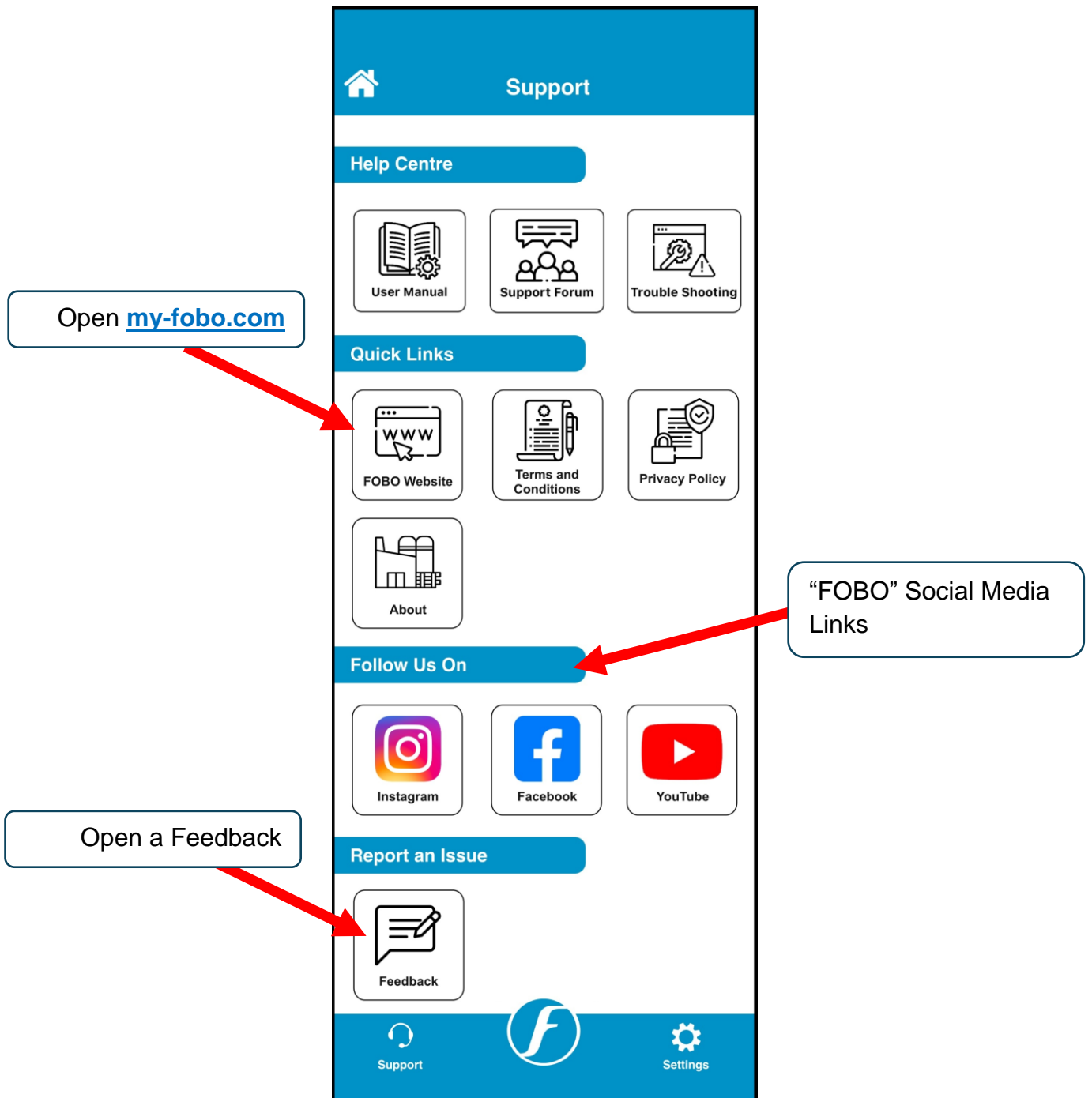



## 6 FOBO TPMS Alert Messages

You will get the following alert messages below on your smartphone during the operation of FOBO TPMS under different conditions. Please find a safe location to stop your vehicle and check the alert messages on the app.

### 6.1 Pressure Below Pre-set Limit

You will receive this soft alert when the tire pressure drops below the pre-set lower limit. The pre-set value for the low limit is 8% below the recommended pressure that you have set. For fuel economy and optimum tire performance, it is recommended to maintain this 8% range so that you can keep your tires inflated optimally. If you find the reminder is too frequent, you may want to check your tire for any leakage. Note that drastic temperature drop may also cause tire pressure drop. Please check your tire pressure and re-inflate during change of seasons.

### 6.2 Pressure Above Pre-set Limit

You will receive this soft alert when the tire pressure increases above pre-set upper limit. The pre-set value for upper limit is 25% above recommended pressure or above 790 kPa, whichever that is lower. You can change this upper limit in the advance settings up to a maximum of 790 kPa. For optimum tire performance and grip, you should not overinflate your car tires. Note that the tire pressure will naturally increase as the car tires heat up due to friction while driving. However, you should check your tire in the event of an abnormal rise in the tire pressure.

**Note: The hard limit for high pressure is fixed at 790 kPa and cannot be change by the user.**

### 6.3 Sensor Battery Level Low

You will receive this soft alert when the sensor battery level drops to certain level. Please change the battery immediately after you receive this alert. You will continue to receive this alert every time you start moving your car until the battery is changed.

### 6.4 Pressure Too Low

You will receive this emergency alert when the tire pressure drops 15% below the recommended pressure that you set.

**NOTE: IT IS DANGEROUS TO RIDE WITH LOW TIRE PRESSURE AND IT MAY LED TO A BLOW-OUT. PLEASE STOP THE VEHICLE AND HAVE THE TIRE CHECKED WHEN YOU RECEIVE THIS ALERT.**

## **6.5 Pressure Too High**

You will receive this emergency alert when the tire pressure is 35% above the car tire recommended pressure that you set or when the tire pressure is above 790 kPa, whichever that is lower.

**NOTE: THIS IS AN ABNORMAL RISE IN THE TIRE PRESSURE. PLEASE STOP THE VEHICLE AND HAVE THE TIRE CHECKED WHEN YOU RECEIVE THIS ALERT.**

## **6.6 Temperature Too High**

You will receive this emergency alert when the temperature detected exceeds 70°C. Note that the temperature inside the tire may be higher than the temperature detected by FOBO TIRE LITE sensors due to the air-cooling effect on the tire valve when the car is moving. It is extremely dangerous to drive when you get this alert message.

**WARNING: WHEN YOU RECEIVE THIS ALERT, PLEASE STOP YOUR CAR IMMEDIATELY AND CHECK THE TIRE!**

## **6.7 Signal Low or Sensor Missing**









You will receive this emergency alert when the App fails to communicate with the tire sensor. It could be the sensor signal is blocked, sensor unit damaged or missing from the tire. If confirmed the sensor is damaged or missing, you could disable the sensor in order to continue using FOBO TIRE LITE with remaining working sensors. Please purchase the sensor replacement immediately. It is not advisable to continue driving without FOBO TIRE LITE actively monitoring one or more of your car tires.

## **6.8 Pressure Drop Too Fast**

For fast air leak, FOBO TIRE LITE will alert the user when it matters the most. **FOBO sensors sense the pressure every 8 seconds**, if the pressure changes more than 15 kPa OVER this time frame, the sensor will immediately send an updated pressure signal to the phone which will trigger

an alert on the FOBO TPMS app in the event the pressure has breached the upper or lower limit (applicable to all 3 alert levels).

Details of colour scheme for different level of alert types:

0 – Pressure Alert	RED	
1 – Lower L3	RED	
2 – Lower L2	ORANGE	
3 – Lower L1	YELLOW	
4 – Normal	WHITE	
5 – Higher L1	YELLOW	
6 – Higher L2	ORANGE	
7 – Higher L3	RED	
8 – Missing	RED	

**Sensor Alert Type  
3 – Lower L1**

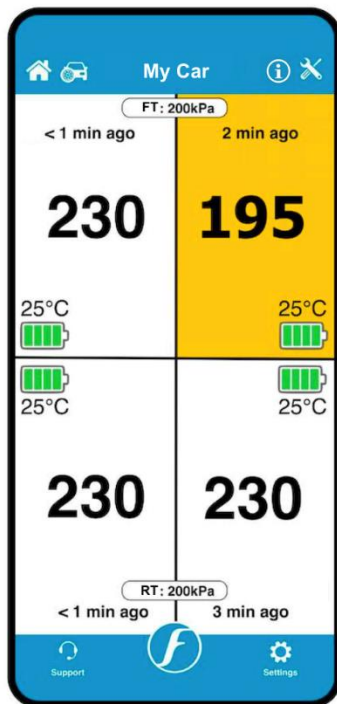

**Sensor Alert Type  
2 – Lower L2**

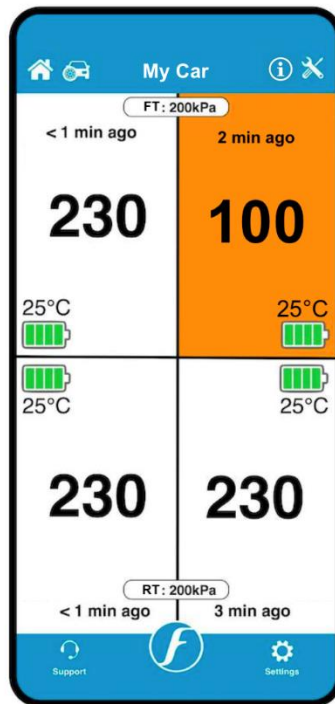

**Sensor Alert Type  
1 – Lower L3**

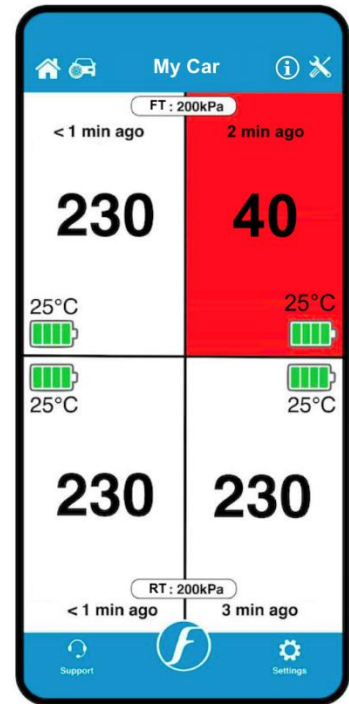

Sensor Alert Type  
5 – Higher L1

Sensor Alert Type  
6 – Higher L2

Sensor Alert Type  
7 – Higher L3

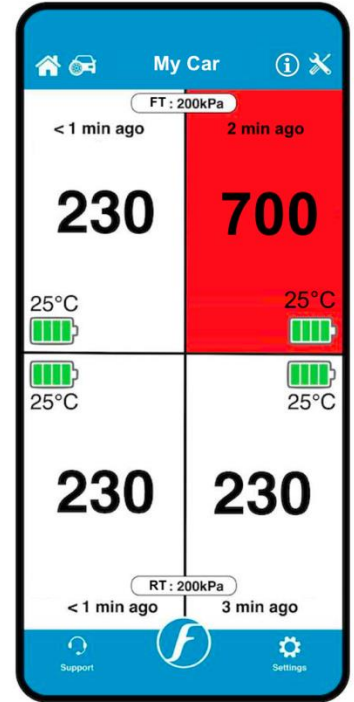
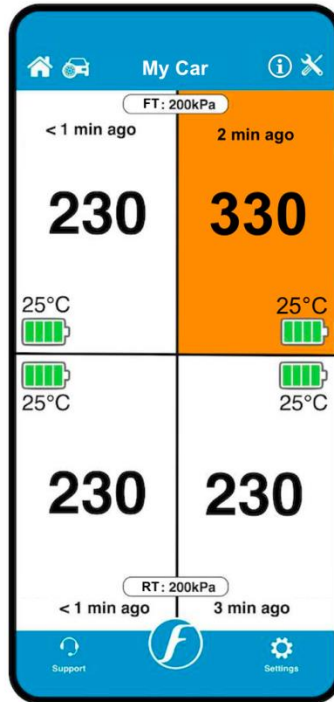
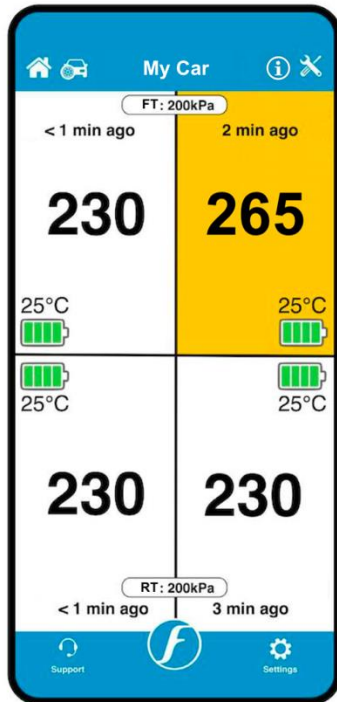

As can be seen in the examples above, the sensor box colour will change according to the pressure level e.g., L1, L2, L3.

**WARNING: FOBO TIRE LITE IS A MONITORING DEVICE TO ALERTS THE USER WHEN IT DETECTS SIGNALS THAT IS OUT OF PRE-SET CONDITIONS BASED ON THE SETTING BY THE USER. THE USER OR DRIVER IS SOLELY RESPONSIBLE TO FIND OUT THE ACTUAL CONDITION OF THE TIRE AND TO ENSURE PROPER TIRE MAINTENANCE. FOBO TIRE LITE IS NOT RESPONSIBLE FOR WRONG DIAGNOSTICS OR FALSE ALERTS THAT MAY CAUSE INCONVENIENCE.**

## Summary of Alerts

Alarm Level	Trigger Point when Threshold Breached	Remarks
1 <sup>st</sup> Level (L1)	8% Below 25% Above	Soft Alerts
2 <sup>nd</sup> Level (L2)	15% Below 35% Above	Emergency Alerts
3 <sup>rd</sup> Level (L3)	45% Above	Emergency Alerts
	Missing Sensor	Emergency Alerts
	High Temperature (Above 70°C)	Emergency Alerts
<b>For further details on the Alerts, kindly refer to Section 6 of this Manual.</b>		

## 7 Replacing Battery

The coin cell battery (CR1632) used in the FOBO TIRE LITE sensors could last up to one year based on normal operating condition. Operating in extreme cold or hot temperatures may reduce battery operating life for the tire sensors.

To replace the battery of sensor unit, unscrew the top cover. Be careful not to damage the rubber gasket as it may affect water resistance of the sensor unit. Ensure the battery (CR1632) is inserted with the “+” sign facing up, away from the PCB.

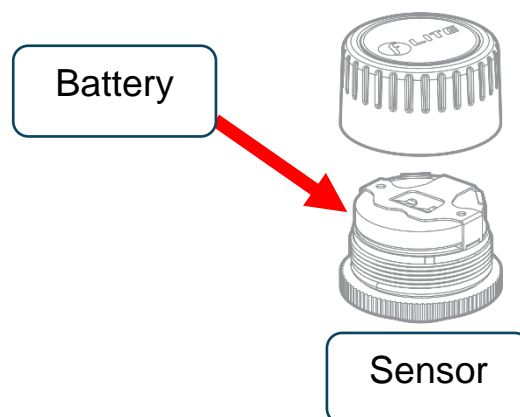

**Note:** It is recommended to remove sensor batteries if you are not going to use them for long time.

## 8 Troubleshooting Guide

Unable to pair FOBO TIRE LITE Sensors

- Make sure the battery is installed correctly, and battery tab is removed.
- Make sure your smartphone has Bluetooth 4.0 (Smart Ready) capability. **NOTE: BLUETOOTH 2.0 OR 3.0 WILL NOT WORK WITH THIS DEVICE.**
- Please check if the FOBO TIRE LITE has been paired before to another FOBO account. You'll need to "Release" the FOBO TIRE LITE set from the FOBO account that it is paired to, before using on your account. The FOBO TIRE LITE is designed to pair with one FOBO account only for theft deterrent feature.
- Try to do a hard reset on the phone.
- Try by turning off/on your smartphone Bluetooth.

Unable to get readings from FOBO TIRE LITE sensors after removing the battery tab.

- Try by removing the sensor battery – wait for 15 seconds – insert back.

## 9 FOBO TIRE LITE Specifications

### FOBO TIRE LITE Sensor (TM1802) Specification:

- **Bluetooth:** v5.0
- **Transmit Conducted Power:** +5.0dBm (sensor)
- **Receiver Sensitivity:** Conducted Sensitivity -97dBm @ 0.1%BER
- **Antenna Return Loss:** Typical -9dB
- **Operating Frequency:** 2.402~2.480 GHz
- **Battery Type:** CR1632 (sensor). Operating life up to 1 year. (NOTE: The battery operating life varies according to usage and climate temperature)
- **Operating Temperature:** -40°C to +85°C (sensor), -20°C to +60°C (sensor with common CR1632 batteries)
- **Weight:** 7.6g (sensor –with battery)
- **Sensor Dimension H x D:** 13.8mm x 20.2mm

- **Maximum Pressure:** 800kPa (116psi)
- **ESD:** 8kV air discharge & 4kV direct contact discharge according to CE standard
- **Operating Humidity:** up to 90% non-condensing at 40°C
- **Dust and Waterproof:** IEC60529 compliant to IP57(sensor)
- **Sensor Structural Threshold:** 100N ball pressure intensity test
- **Mechanical & Environmental Reliability Testing Standards:** IEC 60068-2-2, IEC 60068-2-1, ISO 21750, IEC 60068-2-29, IEC 60068-2-5, IEC 60068-2-32, ISO 15184, ISO 2409, SAE J2657, SAEJ113/13

## 10 Warning

- Take note that FOBO TIRE LITE is not meant to function as anti-accident or anti-injury device. FOBO TIRE LITE is not a substitute for safe tire maintenance practices. Please take full responsibility of your own safety while driving. And continue to send your car for regular tire check and maintenance.
- You shall not use the FOBO TIRE LITE in any unlawful way that violates any laws.
- FOBO TIRE LITE may fail to function properly if the battery is below optimum level. Replace the battery immediately to continue enjoying full features of FOBO TIRE LITE.

### CAUTION

**THERE MAY BE A RISK OF EXPLOSION IF BATTERY IS REPLACED BY AN INCORRECT TYPE. DISPOSE ALL USED BATTERIES PROPERLY.**

## 11 Regulatory Information

### Federal Communication Commission Interference Statement:

This device complies with Part 15 of the FCC Rules. Operation is subject to the following two conditions: (1) This device may not cause harmful interference, and (2) This device must accept any interference received, including interference that may cause undesired operation.

This equipment has been tested and found to comply with the limits for a Class B digital device, pursuant to Part 15 of the FCC Rules. These limits

are designed to provide reasonable protection against harmful interference in a residential installation. This equipment generates uses and can radiate radio frequency energy and, if not installed and used in accordance with the instructions, may cause harmful interference to radio communications. However, there is no guarantee that interference will not occur in a particular installation. If this equipment does cause harmful interference to radio or television reception, which can be determined by turning the equipment off and on, the user is encouraged to try to correct the interference by one of the following measures:

- Reorient or relocate the receiving antenna.
- Increase the separation between the equipment and receiver.
- Connect the equipment into an outlet on a circuit different from that to which the receiver is connected.
- Consult the dealer or an experienced radio/TV technician for help.

FCC Caution: Any changes or modifications not expressly approved by the party responsible for compliance could void the user's authority to operate this equipment.

This transmitter must not be co-located or operating in conjunction with any other antenna or transmitter.

**FOR PORTABLE DEVICE USAGE (<20m from body / SAR needed e.g. BT dongle, smartphone)**

### **Radiation Exposure Statement:**

The product complies with the FCC portable RF exposure limit set forth for an uncontrolled environment and are safe for intended operation as described in this manual. The further RF exposure reduction can be achieved if the product can be kept as far as possible from the user body or set the device to lower output power if such function is available.

**FOR MOBILE DEVICE USAGE (>20cm/low power eg. AP routers)**

### **Radiation Exposure Statement:**

This equipment complies with FCC radiation exposure limits set forth for an uncontrolled environment. This equipment should be installed and operated with minimum distance 20cm between the radiator & your body.

### **Industry Canada statement:**

This device complies with ISED's licence-exempt RSSs. Operation is subject to the following two conditions: (1) This device may not cause



harmful interference, and (2) this device must accept any interference received, including interference that may cause undesired operation.

Le présent appareil est conforme aux CNR d'ISED applicables aux appareils radio exempts de licence. L'exploitation est autorisée aux deux conditions suivantes: (1) le dispositif ne doit pas produire de brouillage préjudiciable, et (2) ce dispositif doit accepter tout brouillage reçu, y compris un brouillage susceptible de provoquer un fonctionnement indésirable.

#### **FOR PORTABLE DEVICE USAGE (<20m from body/SAR needed)**

### **Radiation Exposure Statement:**

The product complies with the Canada portable RF exposure limit set forth for an uncontrolled environment and are safe for intended operation as described in this manual. The further RF exposure reduction can be achieved if the product can be kept as far as possible from the user body or set the device to lower output power if such function is available.

### **Déclaration d'exposition aux radiations:**

Le produit est conforme aux limites d'exposition pour les appareils portables RF pour les Etats-Unis et le Canada établies pour un environnement non contrôlé. Le produit est sûr pour un fonctionnement tel que décrit dans ce manuel. La réduction aux expositions RF peut être augmentée si l'appareil peut être conserve aussi loin que possible du corps de l'utilisateur ou que le dispositif est réglé sur la puissance de sortie la plus faible si une telle fonction est disponible.

#### **FOR MOBILE DEVICE USAGE (>20cm/low power)**

### **Radiation Exposure Statement:**

This equipment complies with ISED radiation exposure limits set forth for an uncontrolled environment. This equipment should be installed and operated with greater than 20cm between the radiator & your body.

### **Déclaration d'exposition aux radiations:**

Cet équipement est conforme aux limites d'exposition aux rayonnements ISED établies pour un environnement non contrôlé. Cet équipement doit être installé et utilisé à plus de 20 cm entre le radiateur et votre corps.

### **European Union Regulatory Conformance**

This equipment is CE marked according to the provisions of the R&TTE Directive (99/5/EC) and follows the essential requirements and other relevant provisions of the Directive 1999/5/EC. This equipment meets the following conformance standards:

EN 300 328, EN62479, EN 301 489-1&17, EN 60950-1

## EU Declaration of Conformity

Hereby, Salutica Allied Solutions Sdn. Bhd. declares that this Bluetooth device follows the essential requirements and other relevant provision of Directive 1999/5/EC.

**Caution:** Changes or modifications to this **FOBO** device not expressly approved by the party responsible for compliance could void the user's authority to operate it.

### Bluetooth Wireless Compatibility:

This **FOBO** device supports the following Bluetooth wireless protocols and profiles:

- Bluetooth core technology v4.0
- Battery Profile (BAS)
- Proximity (PXP)
- Device Information Service (DIS)

### Bluetooth Wireless Interoperability:

This **FOBO** device is designed to be interoperating with all Bluetooth wireless products that support compatible profiles and roles including:

- Bluetooth core technology v4.0
- Bluetooth master and slave roles

## 低功率電波輻射性電機管理辦法

取得審驗證明之低功率射頻器材，非經核准，公司、商號或使用者均不得擅自變更頻率、加大功率或變更原設計之特性及功能。低功率射頻器材之使用不得影響飛航安全及干擾合法通信；經發現有干擾現象時，應立即停用，並改善至無干擾時方得繼續使用。前述合法通信，指依電信管理法規定作業之無線電通信。低功率射頻器材須忍受合法通信或工業、科學及醫療用電波輻射性電機設備之干擾。

## 12 Intellectual Properties

- FOBO™ is a trademark of Salutica Allied Solutions Sdn Bhd. All rights reserved.
- FOBO™ TPMS incorporates a few patent pending technologies solely owned by Salutica Allied Solutions Sdn Bhd.
- Bluetooth® is a registered trademark owned by Bluetooth SIG Inc.
- iPhone® is a registered trademark of Apple Inc.

## 13 Limited Warranty & Disclaimer

### 13.1 Warranty

FOBO TIRE LITE comes with a 12-month limited warranty. This Limited Warranty does not cover: 1) products purchased from an unauthorized reseller; 2) products purchased through online auctions; 3) products that are operated in combination with software, peripheral or ancillary equipment such as but not limited to batteries, chargers, adapters, headsets, connector cables, and power supplies ("Ancillary Equipment") not furnished or otherwise certified by Salutica for use with the FOBO products or any damage to the FOBO products or ancillary equipment as a result of such use; 4) damage caused by (a) accident, fire, misuse, neglect, unusual physical or electrical stress, or modification; (b) improper or unauthorized installation, wiring, repair, testing or (c) use of the product outside Salutica's published guidelines; 5) instances in which someone other than Salutica (or its authorized service centres) tests, alters, modifies or services the products in any way; 6) products that have (a) serial numbers or date tags that have been removed or altered, or (b) nonconforming or non-FOBO housings or parts; and 7) consumable spare parts and accessories (unless they are found to be non-functional or broken upon purchase of product).

To obtain any warranty service, you agree to bear all shipping charges of the FOBO TIRE LITE device to Salutica's address.

### 13.2 Disclaimer

SALUTICA MAKES NO OTHER EXPRESS WARRANTY WHETHER WRITTEN OR ORAL AND SALUTICA EXPRESSLY DISCLAIMS ALL WARRANTIES AND CONDITIONS NOT STATED IN THIS LIMITED WARRANTY. TO THE EXTENT ALLOWED BY THE LOCAL LAW OF

JURISDICTIONS OUTSIDE MALAYSIA, SALUTICA DISCLAIMS ALL IMPLIED WARRANTIES OR CONDITIONS, INCLUDING ANY IMPLIED WARRANTIES OF MERCHANTABILITY AND FITNESS FOR A PARTICULAR PURPOSE. FOR ALL TRANSACTIONS OCCURRING IN MALAYSIA, ANY IMPLIED WARRANTY OR CONDITION OF MERCHANTABILITY, SATISFACTORY QUALITY, OR FITNESS FOR A PARTICULAR PURPOSE IS LIMITED TO THE WARRANTY PERIOD AS PROVIDED BY SALUTICA IN THE MATERIALS RECEIVED AT THE TIME OF PURCHASE.

No warranty is made that the software provided by Salutica will meet your requirements or will work in combination with any hardware or Applications software products provided by third parties, that the operation of the software products will be uninterrupted or error free, or that all defects in the software products will be corrected.

### **13.3 Limitation of Liability**

THE MAXIMUM LIABILITY OF SALUTICA UNDER THIS LIMITED WARRANTY IS EXPRESSLY LIMITED TO THE LESSER OF THE PRICE YOU HAVE PAID FOR THE PRODUCT OR THE COST OF REPAIR OR REPLACEMENT OF THAT PRODUCT OR ANY COMPONENT OR PART THAT MALFUNCTION IN CONDITIONS OF NORMAL USE. EXCEPT AS INDICATED ABOVE, IN NO EVENT WILL SALUTICA BE LIABLE FOR ANY DAMAGES CAUSED BY THE FOBO TIRE LITE PRODUCT OR THE FAILURE OF THE PRODUCT TO PERFORM, INCLUDING ANY LOST PROFITS OR SAVINGS OR SPECIAL, INCIDENTAL, OR CONSEQUENTIAL DAMAGES. SALUTICA IS NOT LIABLE FOR ANY CLAIM MADE BY A THIRD PARTY OR MADE BY YOU FOR A THIRD PARTY. THIS LIMITATION OF LIABILITY APPLIES WHETHER DAMAGES ARE SOUGHT, OR A CLAIM MADE, UNDER THIS LIMITED WARRANTY OR AS A TORT CLAIM (INCLUDING NEGLIGENCE AND STRICT PRODUCT LIABILITY), A CONTRACT CLAIM, OR ANY OTHER CLAIM. THIS LIMITATION OF LIABILITY CANNOT BE WAIVED OR AMENDED BY ANY PERSON. THIS LIMITATION OF LIABILITY WILL BE EFFECTIVE EVEN IF YOU HAVE ADVISED SALUTICA OR AN AUTHORIZED REPRESENTATIVE OF SALUTICA OF THE POSSIBILITY OF ANY SUCH DAMAGES. THIS LIMITATION OF LIABILITY, HOWEVER, WILL NOT APPLY TO CLAIMS FOR PERSONAL INJURY.

### **13.4 What Law Governs This Warranty**

THIS LIMITED WARRANTY IS GOVERNED BY AND CONSTRUED UNDER THE LAWS OF MALAYSIA.